

Product Manual of S-RTK100A

(Multi-functional Portable RTK Module)

202310

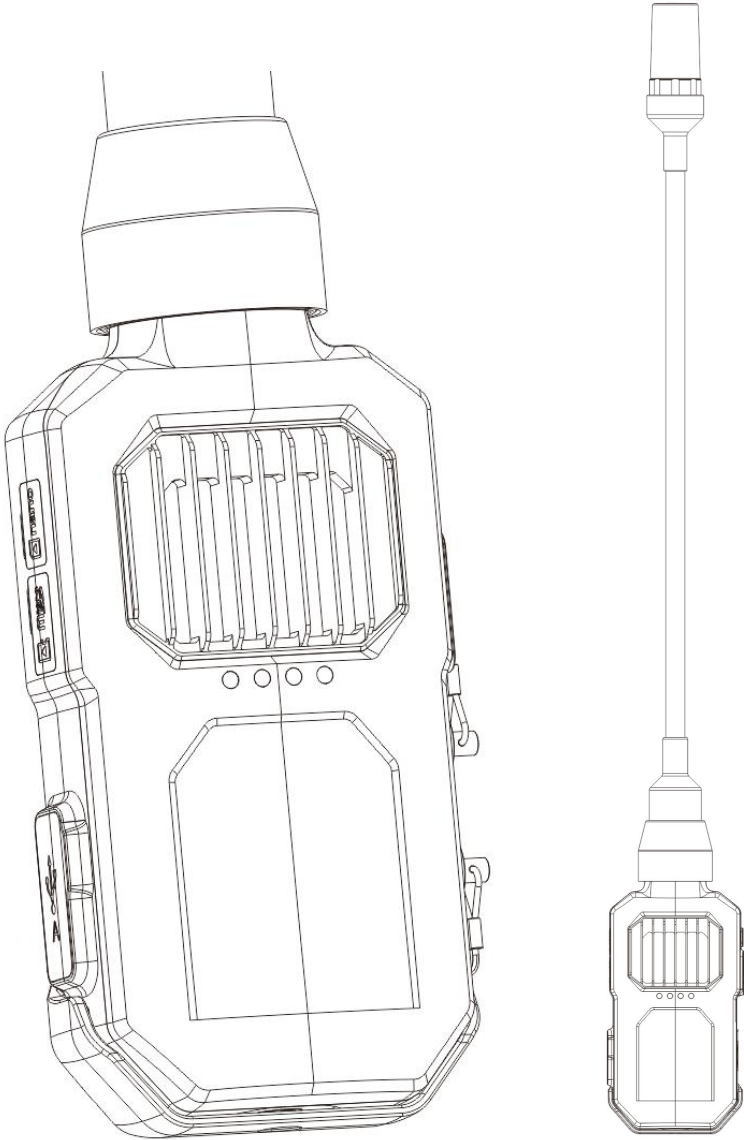

Shenzhen Feima Robotics Co., Ltd.

Disclaimer

Thank you for choosing the S-RTK100A product.

The content mentioned in this article relates to your safety, legal rights and responsibilities. Before using this product, please read this article carefully to ensure that the product has been correctly set. Failure to follow the instructions and warnings herein may damage S-RTK100A or its accessories. Feima Robotics Co., Ltd. (hereinafter referred to as **Feima Robotics**) reserves the right to final interpretation of this document and all relevant documents of S-RTK100A. It is subject to update without notice.

Once you use this product, you will be deemed to have carefully read the disclaimer and warning, understood, recognized and accepted all the terms and contents of this statement. You promise to take full responsibility for the use of this product and the possible consequences. You promise to use this product only for legitimate purposes, and agree to these terms and any relevant regulations, policies and guidelines formulated by Feima Robotics.

Except for the provisions of current laws and regulations in China, Feima Robotics is not responsible for the loss, injury and any legal liability caused by the direct or indirect use of the product and this document. Users shall follow all safety guidelines, including but not limited to those mentioned herein.

Feima Robotics reserves the right to change this product manual and product status. Please download the latest version of the product manual on the official website of www.feimarobotics.com/en.



This trademark is the trademark of Feima Robotics Co., Ltd. and its affiliated companies. The product names and brands appearing in this article are trademarks or registered trademarks of the companies to which they belong.

S-RTK100A is a relatively precise instrument. Users should have the basic hands-on ability and safety knowledge and should use it carefully. Please read the S-RTK100A product manual first and be familiar with the product functions before using it. The uncertain operation may lead to product damage and property loss. This product is not suitable for children. Do not use the products that are not provided or recommended by Feima Robotics, or do not follow the safety guidelines mentioned in the product documentation provided by Feima Robotics. To ensure that you can use S-RTK100A correctly and safely, please read the product manual carefully before installing, setting up and using it, and install and use S-RTK100A in strict accordance with the relevant instructions.

Catalog

Disclaimer	2
Catalog	3
Introduction to S-RTK100A	4
S-RTK100A Packing List	4
Component Description	5
Performance Parameters	6
Hardware Parameters	6
Performance parameters	7
4G Module Parameters	7
Basic characteristics	7
Transmission rate	7
Antenna specification	7
Indicator Description	8
Assembly Instructions	10
S- RTK100A with SLAM100 Assembly	11
S- RTK100 Used alone	15
S-RTK100A setting	17
Firmware Setup	17
Appendix	18
More combination connection methods	18
Endurance	18
Storage	19
S-RTK Operation Guide	20
SLAM GO APP Introduction	20
SLAM GO registration and login	21
Personal Center	23
Connect/disconnect S-RTK100A	27
Device status	31
Settings	43
File	49
Measurement	58
Contact us	61

Introduction to S-RTK100A

S-RTK100A is a high-precision satellite signal receiver system independently developed by Feima Robotics, supporting global mainstream satellite navigation systems. It uses multiple data transmission paths and efficient sensors to provide real-time differential data, enabling it to obtain centimeter-level 3D positioning data, providing accurate and reliable system solutions for high-precision application needs. S-RTK100A supports multiple global positioning systems and multi-frequency satellite signal reception. Users can assemble with SLAM100 laser scanners, mount backpacks, or use them separately as mobile RTK devices, with flexible application forms and high accuracy in obtaining positioning data.

When used in conjunction with the S-PACK100 backpack, the S-RTK100A can also be connected to a high-gain GNSS antenna, allowing it to receive more satellite signals, search for more satellites, and achieve better results. Even in harsh environments with weak signals, it can still receive and locate satellites normally.

S-RTK100A provides 4G communication mode, enabling users to stably obtain data. S-RTK100A has high sealing performance, good waterproof and dustproof performance, small size, lightweight, convenient carrying, simple installation and use, and can support the collaborative operation of multiple products of Feima Robotics to improve production efficiency.

S-RTK100A Packing List

No	Description	Model	Qty
1	S-RTK100A Measuring Instrument	S-RTK100A	1
2	Aerial plug connection cable	/	1
3	Card Reader	High speed reader(SD+TF)	1
4	Certification	/	1
5	Product Manual	/	1
6	Warranty Card	/	1

Component Description

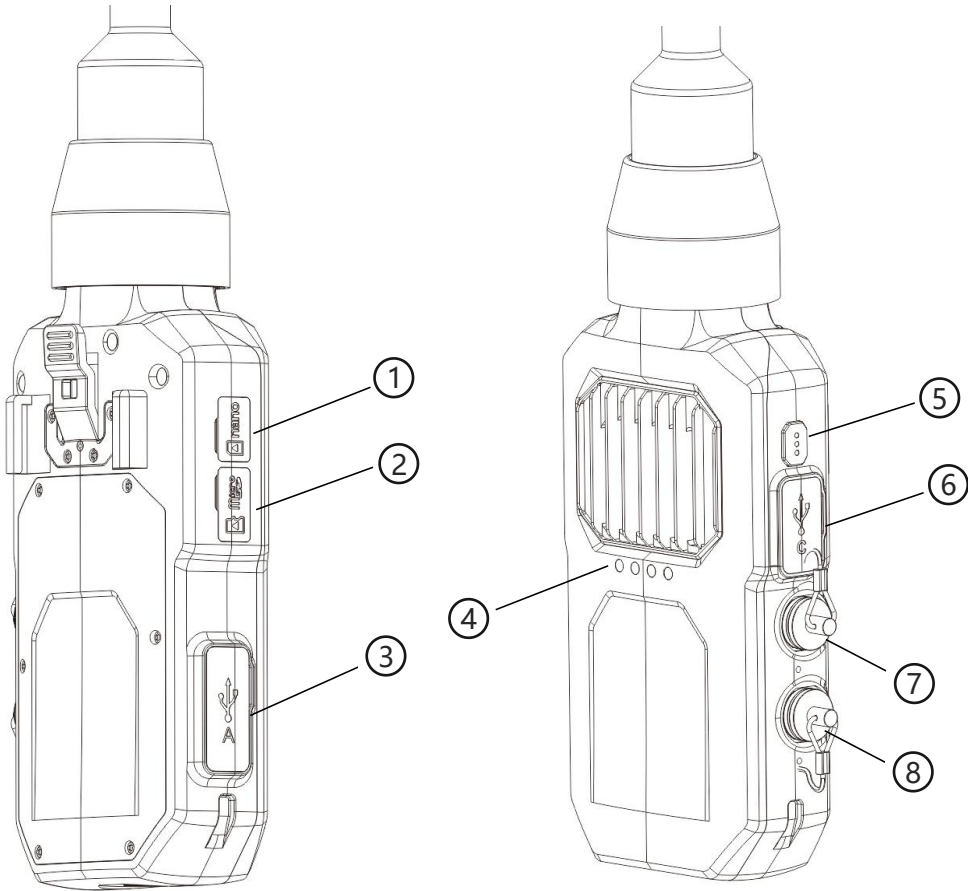

- ① Nano-SIM slot
- ② MicroSD slot
- ③ USB-A port
- ④ Pilot lamp

- ⑤ Function keys (Customizable)
- ⑥ Type-C(20V)
- ⑦ Circular Connector-1
- ⑧ Circular Connector-2

Performance Parameters

Hardware Parameters

Parameters	Materials	Plastic, aluminum alloy
	Size	39mm×80 mm×146 mm (not include antenna) 39mm×80mm×595mm (include antenna)
	Net Weight	288.5g(include antenna) 197g(not include antenna)
	Weight of Mounting Kits	20g
Environmental Characteristic	Protection Grade	IP54
	Operating Temperature	-20°C~50°C
	Storage Temperature	-20°C~55°C
Power Supply	Type-C External Power Supply	20V
	Circular Connector Power Supply Input Range(Aviation port)	12V-20V
Data storage	Memory card requirements	MicroSD 32GB Speed C10 or above (standard) Maximum support up to 64G, including 64G, Speed C10 or above

Notice!

- S-RTK100A is splash-proof, water-proof and dust-proof when all ports and protective covers are tightly closed. It has been tested under controlled laboratory conditions and its effect reaches IP54 level under the IEC 60529:2013 standard. Splash resistance, water resistance, and dust resistance are not permanent, and protection performance may decrease due to daily wear and tear. Do not use S-RTK100A in severe weather conditions such as rain, snow or lightning.
- When any port and protective cover of S-RTK100A are opened, the protection level will not be guaranteed. Pay Note to waterproof and dustproof during use.
- Please refer to the user manual for cleaning and drying instructions, damage caused by immersion in liquid is not covered by the warranty.
- It is recommended to use the standard storage card of the product. If other models of storage cards are needed, the capacity requirement is not greater than 64GB, and the minimum speed requirement is C10 speed level.

Performance Parameters

Satellite signals tracked	BDS B1/B2 GPS L1/L2 GLONASS L1/L2 Galileo E1/E5b*
Single point positioning (RMS)	Horizontal: 1.5m Vertical: 3.0m
DGPS(RMS)	Horizontal:0.4m Vertical:0.8m
RTK(RMS)	Horizontal: 1cm+1ppm Vertical: 1.5cm+1ppm
Data format	NMEA-0183, Unicore*
Position rate	20Hz
Time accuracy (RMS)	20ns
Speed accuracy (RMS)	0.03m/s

4G Module Parameters

L610-CN-62	Support LTE FDD/TDD、GSM、BLE4.2
------------	--------------------------------

Basic characteristics

LTE FDD	Band 1/3/5/8
LTE TDD	Band 34/38/39/40/41
GSM	900/1800MHz

Transmission rate

LTE FDD Rel.13	10Mbps DL/5Mbps UL
LTE TDD Rel.13	8.2Mbps DL/3.4Mbps UL
GPRS	85.6kbps DL/85.6kbps UL(multi-slot class 12)

Antenna specification

Four-arm helical antenna parameters

Connector model	SMA-J
Antenna size	27.5 mm×56 mm
Antenna weight	15.3g +/-1 g
Color	Black

Indicator Description

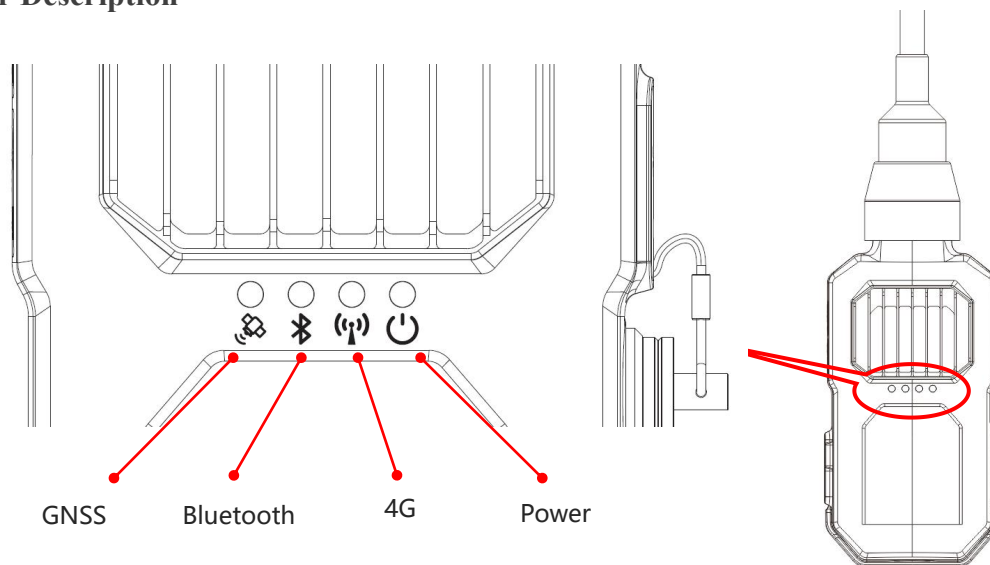

Indicator	Function	Device status	Indicator light status				
			Red	Green	Blue	Yellow	White
GNSS	Positioning	Search satellites	Flicker				
		Single point positioning	Constant lighting				
		Pseudo range Positioning				Flicker	
		Floating point positioning		Flicker			
		Fixed positioning		Constant lighting			
		Fixed positioning, PDOP not meeting requirements		Slow flashing			
		Static Station Mode				Constant lighting	
		Positioning system is initializing		Slow flashing			
Bluetooth	Bluetooth	Bluetooth preparation	Flicker				
		Initialization successful, Bluetooth disconnected status	Constant lighting				
		Bluetooth connection successfully		Constant lighting			
4G	Communication	The data is not ready	Flicker				
		SIM card read successfully		Flicker			
		Connect to 4G network		Constant lighting			
		Differential data		Flash			

		available					
		No SIM card or unrecognized			Flicker		
		Detect firmware version					Slow flashing
		Hardware Download					Flash
Power	Power	Without Micro SD card installed	Flicker				
		USB access	Constant lighting				
		The system is working properly		Flicker			
		MicroSD card data write error			Constant lighting		
Update light	Update	USB Mode ※	All red lights flicker				
		Updating	All green lights flicker				
		Update Failed (Fault)	All blue lights constantly lighting				

- ※ Flash——Frequency 0.06 S, Bright 0.03 S.
- ※ Flicker——Frequency 1 S, Bright 0.5 S.
- ※ Slow flashing——Frequency 2 S, Bright 0.5 S.
- ※ USB Mode——S-RTK100A interacts with a PC or other device through a USB interface, and hardware upgrades cannot be performed in this mode.

Assembly Instructions

Antenna assembly

Connect and tighten the feeder terminal to the S-RTK100A host terminal.

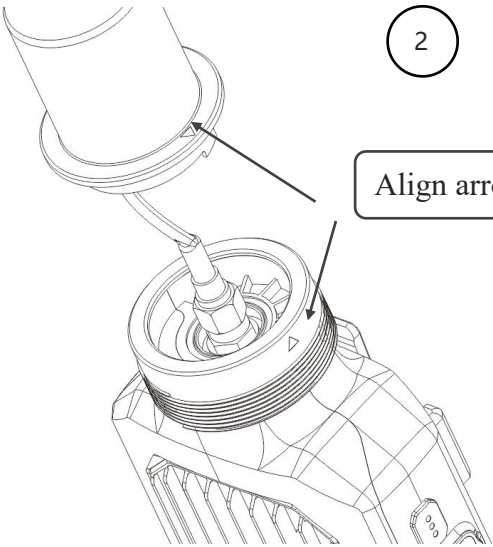
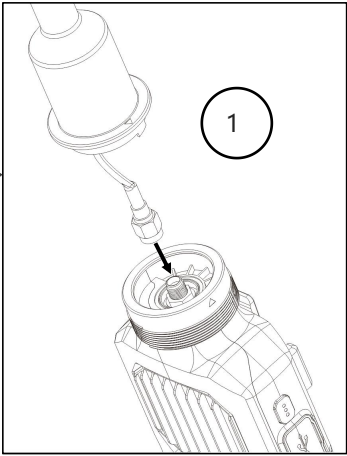

Align arrow markings up and down.

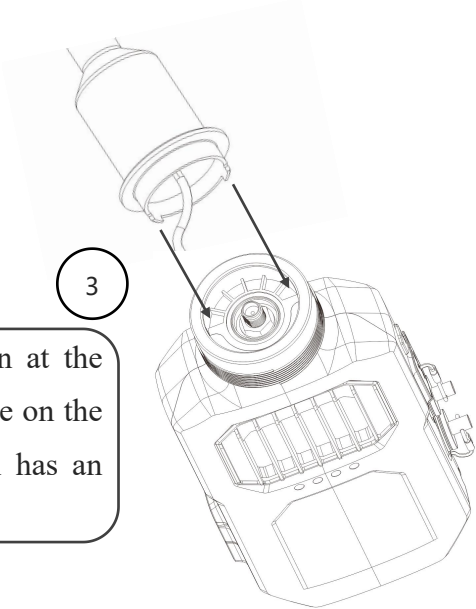

Insert the protruding positioning pin at the bottom of the antenna into the groove on the top of the S-RTK100A host, which has an anti- reverse insertion design.

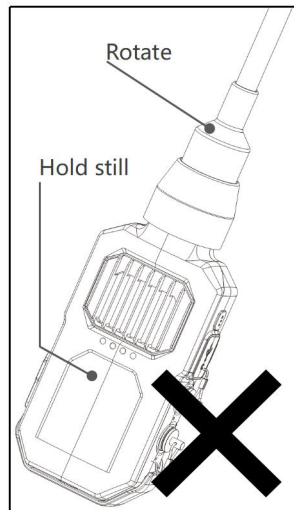
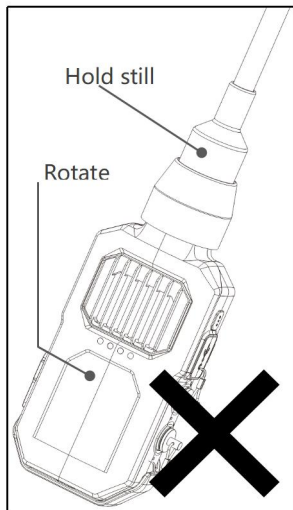
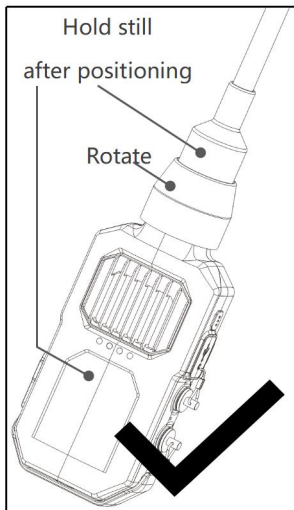
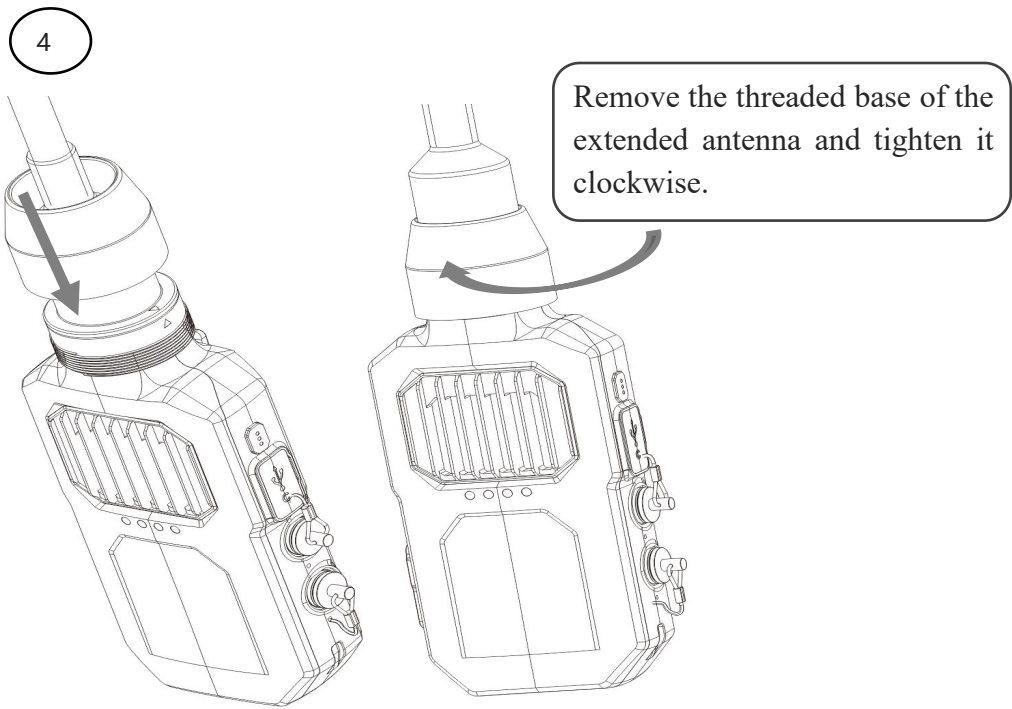

Notice!

- The feeder terminal is a precision component. Please be careful when using.
- To avoid damage to the antenna, when the feeder terminal is connected to the S-RTK100A device body, the S-RTK100A device body cannot rotate relative to the extended antenna.

S-RTK100A with SLAM100 Assembly

① Fix the S-RTK100A bracket to the back of SLAM100 with the six flat head screws.

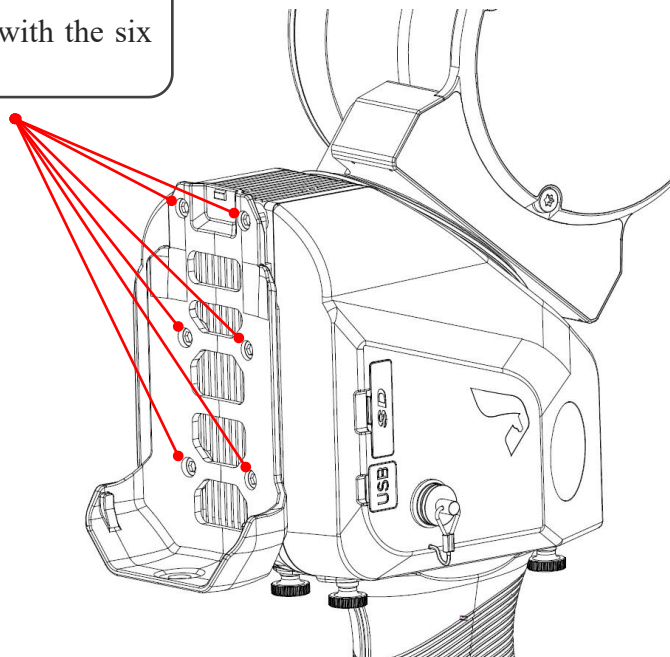

② Insert the S-RTK100A vertically into the bracket from top to bottom, and fix it firmly.

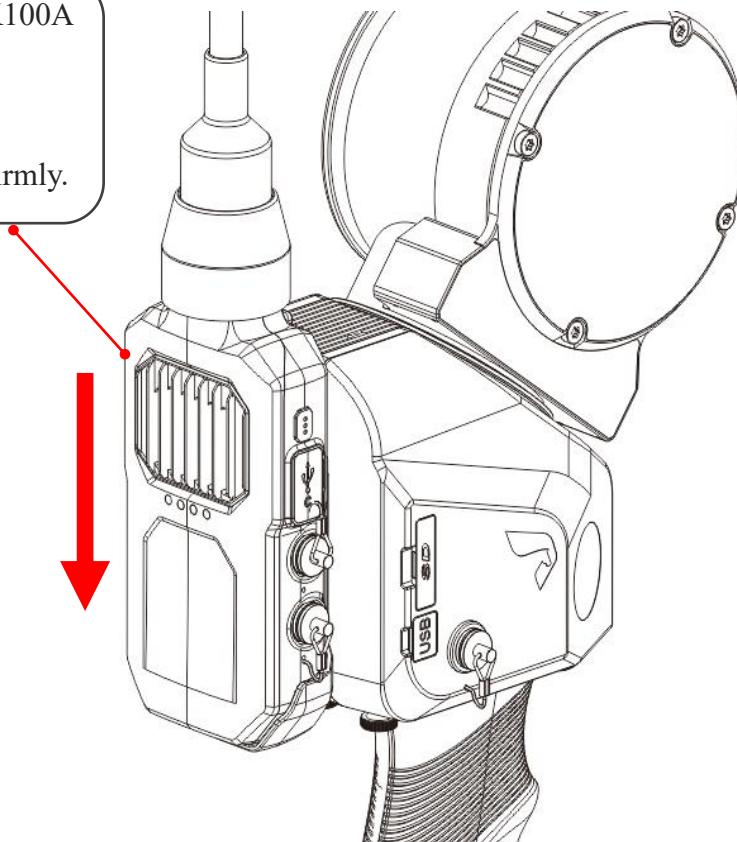

③ Connect the SLAM100 to any circular connector port on the S-RTK100A through the circular connector cable, and pay Note to aligning with the red mark point of the circular connector.

Circular connector port.

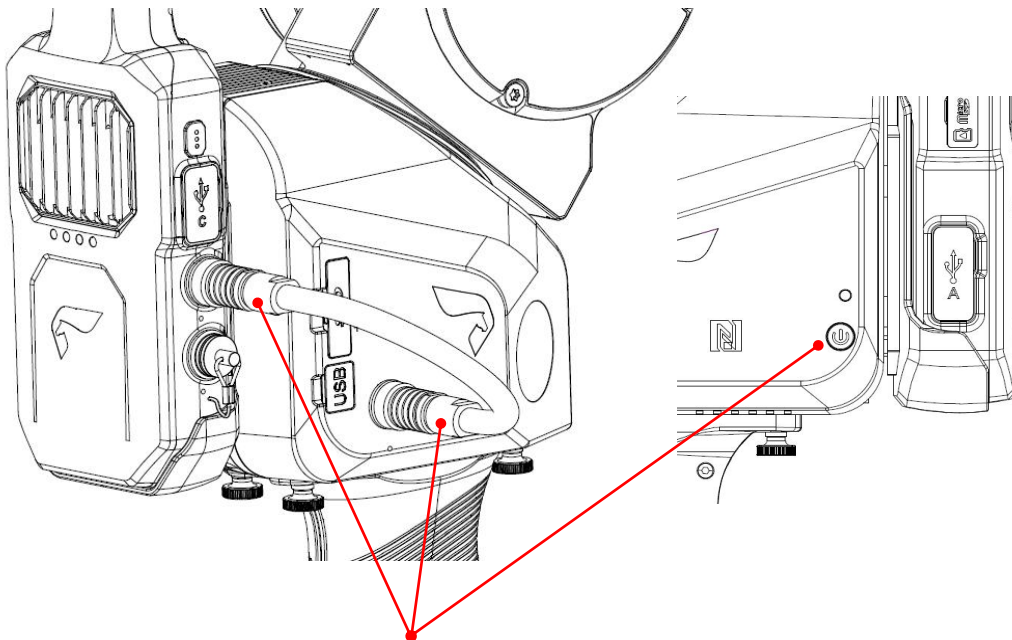
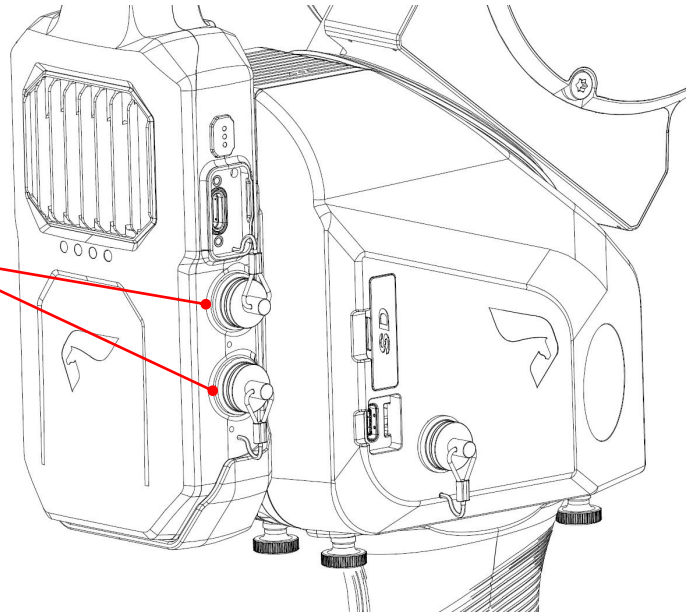

④ Please make sure that the power supply of SLAM100 is normal, press and hold the power button of SLAM100 to turn on, after SLAM100 is turned on, S-RTK100A will automatically turn on and enter the working mode.

Remove S-RTK100A

Press the elastic arm of the back clip, hold the S-RTK100A body and pull it out vertically (lifting the antenna is prohibited)

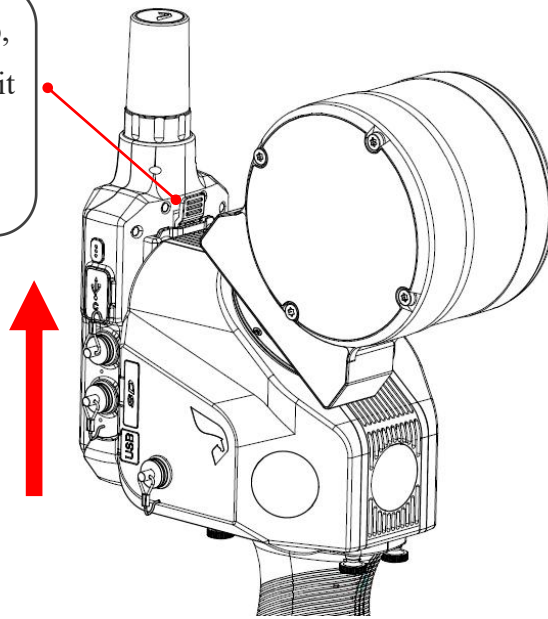

S-RTK100 Used alone

Work alone mode

- 1) S-RTK100A can be supplied by PD power bank, S-RTK100A will be powered on when it is connected to the PD power bank.

Take off the cover on Type-C.

Insert the Type-C data cable, and connect the S-RTK with the power bank.

- 2) The power bank should have a TYPE-C port and support 20V power supply standards (same as the requirements for power bank by SLAM100).
- 3) The S-RTK100A is equipped with a 1/4 inch screw port at the bottom, which can be connected to a **Portable centering pole** through an **Adapter** (this product package does not include **Adapter** and **portable centering pole**, which can be purchased separately if needed)

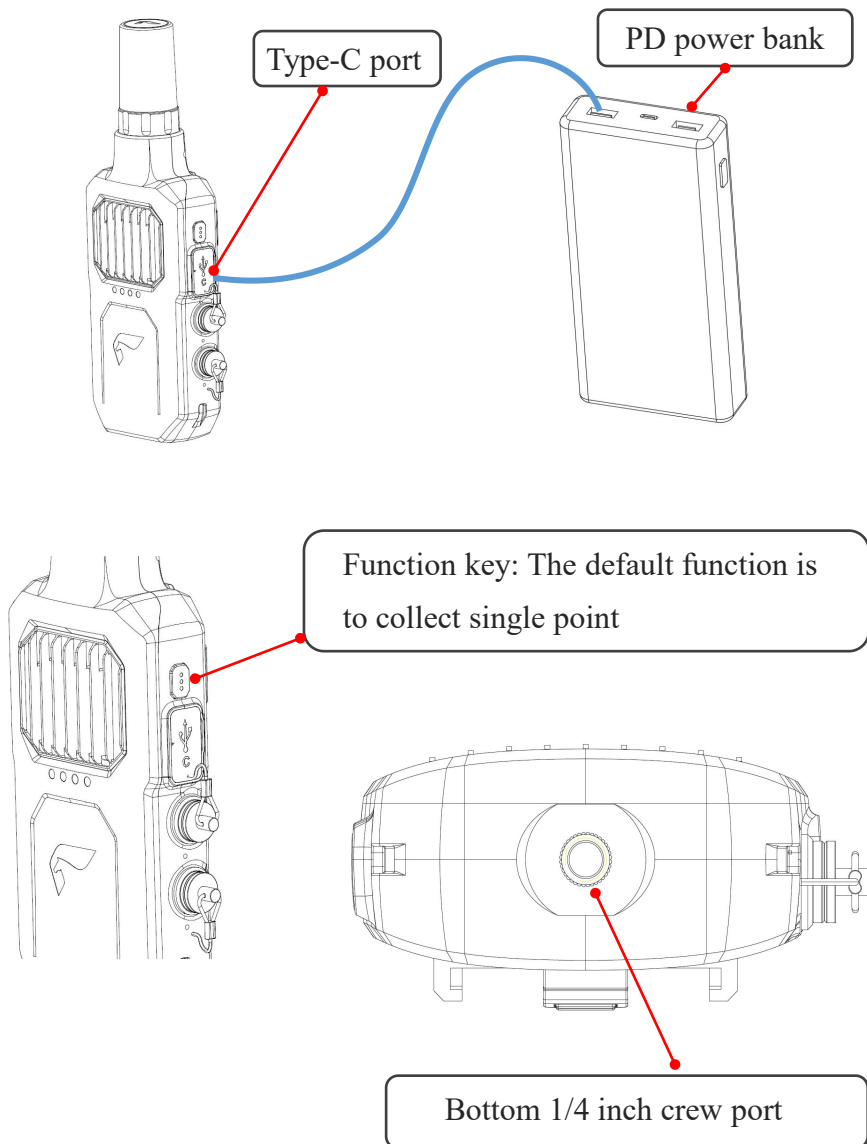



Recommended selection of power bank

Description	Specification	Model
PD Power Bank	20000mAh Support PD 20V 2A	\

Notice!

Selection requirements for mobile power supply (power bank):

- 1) Support protocol control of 20V voltage output.
- 2) The output power shall not be less than 40W.
- 3) The output end of the power exchange module is a Type-C interface, and the connecting cable needs to be purchased separately.
- 4) It is recommended to use the original power cord of the power bank for power connection.

Notice!

When using the power bank to power S-RTK100A, if you find that the device light is not on, please check:

Is the power bank using the correct power cable?

- In theory, if the power bank outputs a 20V voltage, a Type-C to Type-C cable must be used to power the device.
- If the Type-A interface on the power bank is used and a Type-A to Type-C cable is used for the power supply, it is possible that the device light may not light up due to insufficient voltage and the device may not work.

※ Notes: All specifications of S-RTK100A equipment are subject to change without prior notice.

S-RTK100A setting

The specific operating steps for **S-RTK100A** can be found in the **SLAM GO** section **S-RTK100A**.

Notice!

- Please install the 4G-Nano SIM card and TF card into the corresponding slot of S-RTK100A before use.

Firmware Setup

S-RTK100A supports manual firmware upgrades.

Firmware upgrade steps:

- 1) When there is a firmware update, the **SLAM GO APP** will prompt you to download the latest version of the firmware (SRTK100_vxxxx.fm file) according to the prompt path.



- 2) If this is your first time using the device, please insert the TF (microSD) card that comes with the device into the corresponding slot of S-RTK100A.
- 3) Turn on the **S-RTK100A** and wait for the power indicator light to turn green before turning it off. Remove the TF (microSD) card.
- 4) Use the standard card reader provided with the device to read the TF (microSD) card, which can be seen in the Firmware folder directory. Copy the downloaded firmware file to this folder.

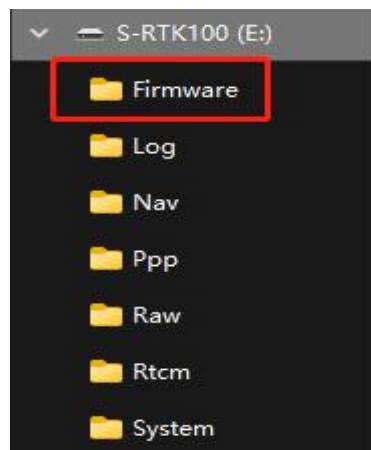

- 5) Insert the TF (microSD) card into the S-RTK100A device again and turn it on. After a while, the four indicator lights turn from green to red to indicate a successful upgrade. After successful upgrade, the four indicator lights will enter a normal indicating state, and the upgrade is complete.

※ If the TF (microSD) card has been used in the **S-RTK100A** device before, the steps ① ②③ can be ignored.

Appendix

More combination connection methods

S-PACK100+S-RTK100A+SLAM100 Set

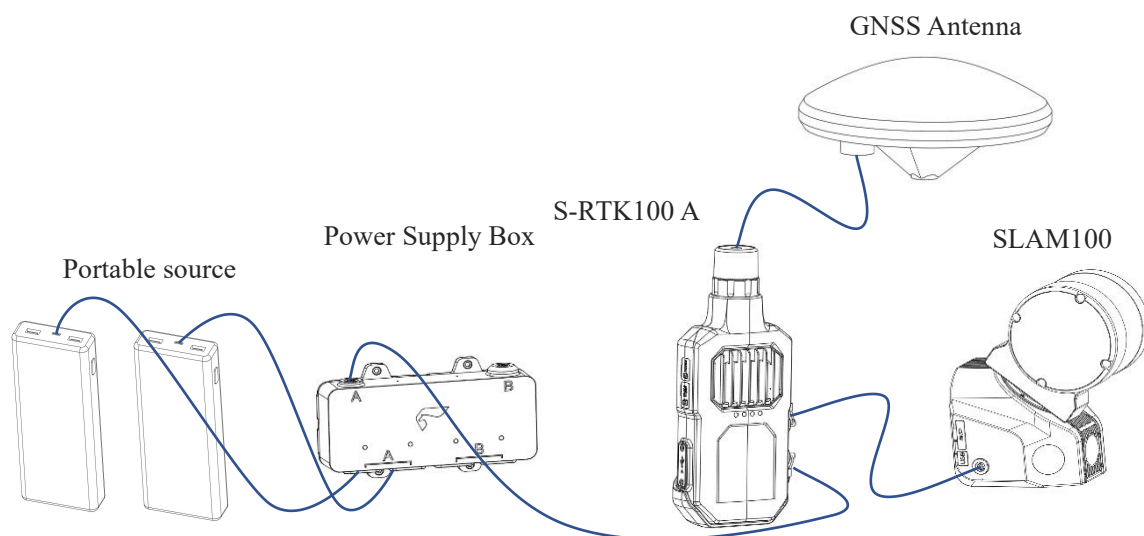

Endurance

Device endurance test (for reference only)

Power supply	Qty	Device	Endurance
12000mAh power bank	×1	S-RTK100A	10h
12000mAh power bank	×2	S-RTK100A	20h
12000mAh power bank	×1	SLAM100+ S-RTK100A	3h
12000mAh power bank	×2	SLAM100+ S-RTK100A	6h

Notice!

- This data is indoor test data at room temperature, for reference only.
- The endurance time may be greatly affected by factors such as the number of charging and discharging cycles and temperature changes of the power bank.

Cleaning

- 1) Use a soft bristle brush to preliminarily clean the appearance of the equipment, gently brushing away dust and other particles.
- 2) Pour diluted alcohol into a spray bottle (30% alcohol content), and spray a piece of non-woven fabric gently. The effect of microfiber cloth is better (do not use paper towels). Gently wipe the equipment body to remove liquid stains and other dirt.
- 3) Clean the corners and sockets, do not use cotton swabs, but use non-woven foam materials.

Notice!

- Do not spray detergent directly onto the device.

Storage

Notice!

S-RTK100A belongs to precision electronic device, please pay Note to the following items for storage:

- 1) Stay away from magnetic fields.
- 2) Preventing falls.
- 3) Prevent squeezing.
- 4) Stay away from damp environments.

If you do not use this device for a long time, please store S-RTK100A or other electronic devices in a safe and dry environment that avoids direct sunlight. It is recommended to store at a temperature of 5-28 °C.

S-RTK Operation Guide

SLAM GO APP Introduction

SLAM GO APP is a high-end companion APP for SLAM100, realizing an efficient solution for lightweight mobile real-time viewing and processing of scanned data. The APP can connect to SLAM100 wirelessly, display 2D and 3D scan data in real time, and support real-time viewing of the 3D modeling and its own positioning. In real application scenarios, the diverse functions of SLAM GO will greatly improve the work efficiency and convenience of users, and it has become the preferred application of many professionals.

System Requirement

Android 8.0 and above operating system.

iPhone iOS 12.0/iPad iPadOS 12.0 and above operating system.

Installation Method

【Chinese users】 Android Version Download link: <http://ios.feimarobotics.com/3vu9>

Users can also scan following QR Code to get the install file.



SLAM GO

【Chinese users】 iOS version download method: search SLAM GO in App Store to get it.

【Overseas users】 Google play store & Apple store

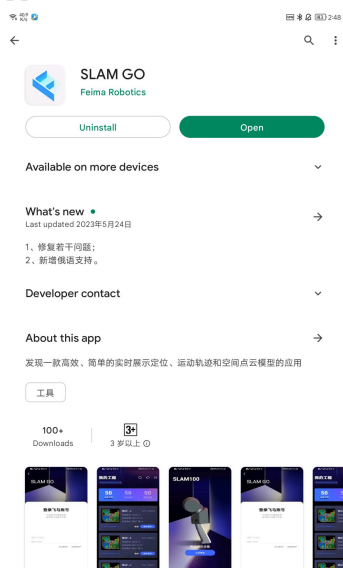

Note: (The S-RTK interface style of SLAM GO APP may vary with the iteration of SLAM GO version. The illustration pictures described below may be inconsistent with the actual interface of SLAM GO you are currently using, please refer to the interface of the latest version of SLAM GO.)

SLAM GO registration and login

Register Feima account

Phone number registration

On the homepage of the app, click **User** and **Register New User** to enter the registration page. Select the correct international area code (for example, China's international area code is+86), fill in the correct phone number, and obtain the verification code. Enter a password with a length of ≥ 6 characters. Check the **Read and Agree to User Agreement and Privacy Policy** option at the bottom of the page and click **Register**. After registration is completed, you can log in, and this account can log in to all products under Feima Robotics.

Email registration

On the homepage of the app, click **User**, click **Register New User**, and then click **Email Registration** to enter the email registration page. Enter the correct email address (for example xxx@outlook.com)Obtain the verification code. Enter the password and confirm it, with a password length of ≥ 6 characters. Check the **Read and Agree to User Agreement and Privacy Policy** option at the bottom of the page and click **Register**. After registration is completed, you can log in, and this account can log in to all products under Feima Robotics.

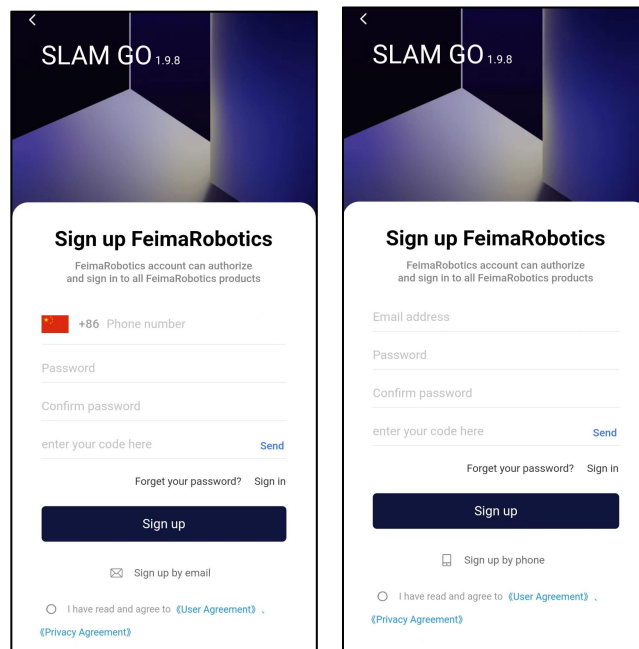

Register a Feima account on your phone/email

Account Login

Log in with your phone number

Open the SLAM GO app and click **User** to select the correct international area code (for example, China's international area code is+86) on the pop-up login page. Fill in the Pegasus mobile account and password, check the **I have read and agree to User Agreement** option at the bottom of the page, and click **Sign in**.

Email login

Open the SLAM GO app and click **User**. On the pop-up login page, click **Sign by email**, fill in the Pegasus email account and password, check the **I have read and agree to User Agreement** option at the bottom of the page, and click **Sign in**.

Other login portals:

- 1) Click on **S-RTK** on the main interface to log in.
- 2) Click on **Login Account** under **Project - My Project** to log in.

You can reset your password by entering the **User** interface and clicking on the **Safe Center** option if you forget your password. Alternatively, enter the **Forgot Password?** section on the login page and follow the prompts to retrieve the password.

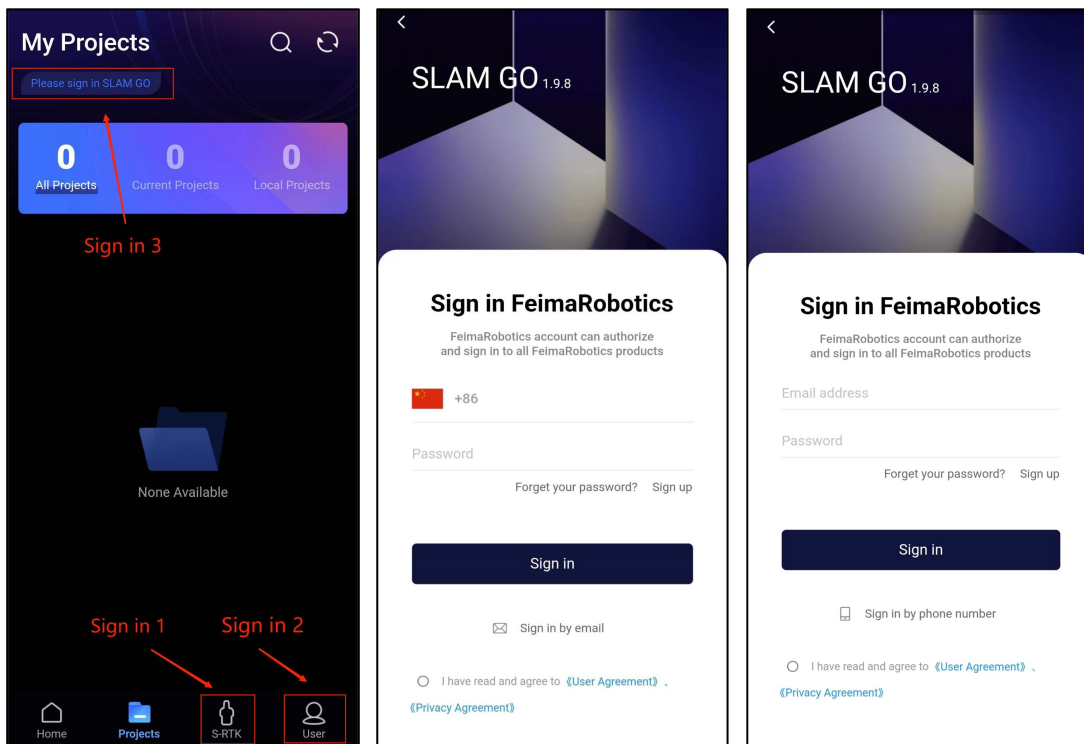

Log in with phone number/email account

Personal Center

Personal Center - **User** includes displaying user names and head portrait, modifying user names, Safe center, viewing activate history, language, Permission and privacy, feedback, about SLAM GO, and sign out.

To install SLAM GO for the first time, you need to click on **User** login in the personal center to use all the functions of the app.

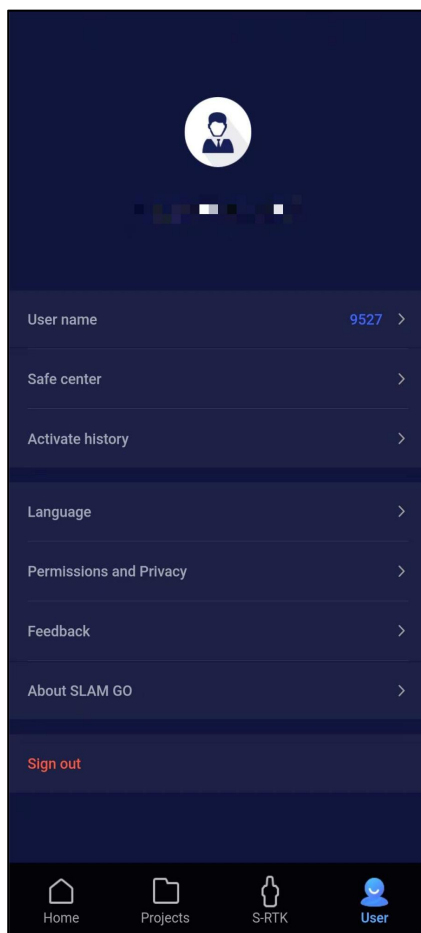

User page

Change login password

Click on **Safe Center - Change Password** in the personal center, enter the old password, and new password, and confirm the new password in the input box. Click **Confirm** to make the modification successful. The system will automatically exit the current account. Please reopen the software to log in.

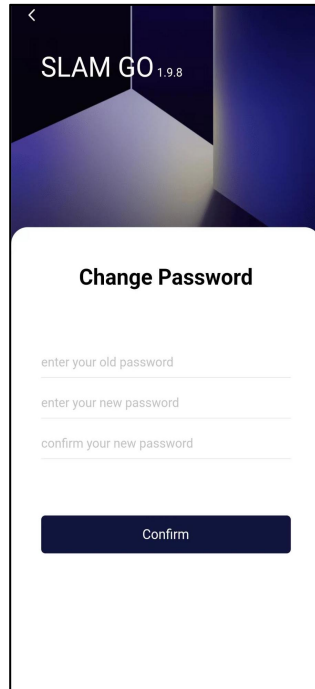

Change login password

Activation Request

Click on the **Activate history** button on the User page to view the activation status of all SLAM100 scanners under the current account.

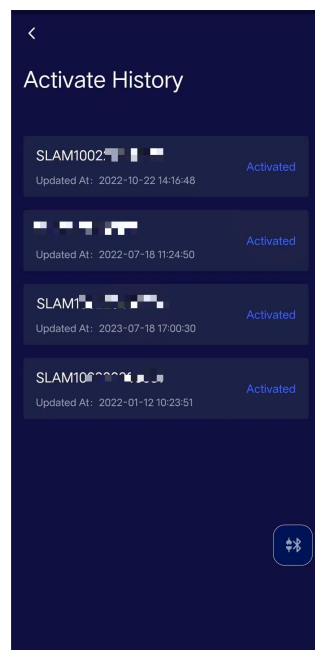

Activation Request

Language setting

SLAM GO supports multiple languages, including Chinese, English, Italian, German, and more.

Click on **User - Language**, and in the Select Language pop-up window, you can select the language you want to switch (when SLAM GO is first started, the default language of the app is the same language as your system).

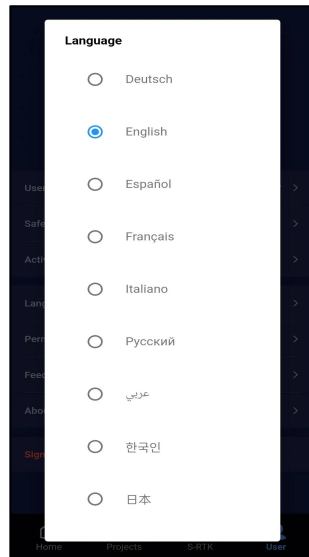

Language setting

About SLAM GO

You can view the latest version information of the current app, the current version information, the copyright ownership information of the app, and download and upgrade the latest version.

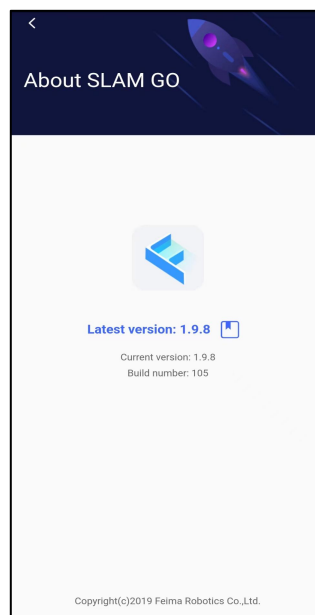

About SLAM GO

Software upgrade

When entering the SLAM GO homepage or entering **User** → **About SLAM GO**, the app will automatically perform version update detection (requires internet connection). If it is the latest version, the **Upgrade Now** button will be displayed at the bottom of the APP homepage or the **About SLAM GO** page. Click **Upgrade Now**, and SLAM GO will automatically download the latest installation package. Click **Install** to update to the latest version.

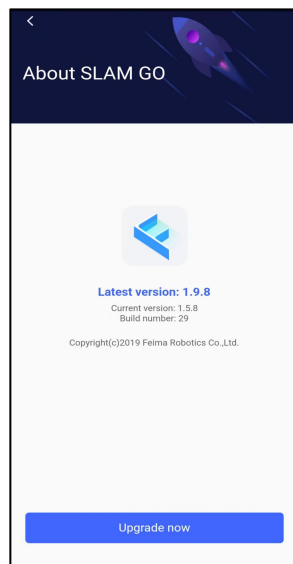

Version Upgrade

Exit Login

Click **Sign out** to exit the currently logged in account and return to the login page.

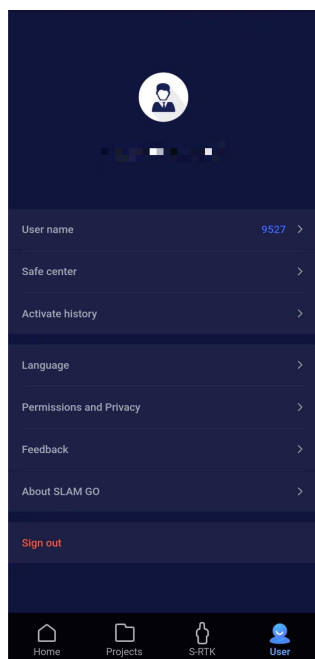

Exit Login

Connect/Disconnect S-RTK100A

Connect S-RTK100A

- 1) S-RTK100A power on and turn on.
- 2) Turn on Bluetooth on the mobile phone, scan for new devices, and find the S-RTK100A device in the Bluetooth search bar for pairing (no password, automatic pairing). If a pop-up prompts for Bluetooth permission usage, please click Always Allow. If multiple S-RTK100A devices are turned on at the same time, you need to turn off other S-RTK100A devices to connect to the specified device, otherwise, there is a possibility of device connection errors.

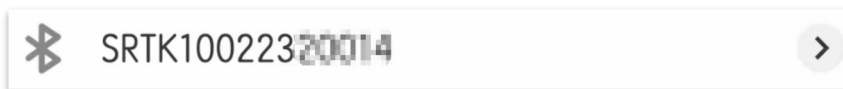

- 3) After successful pairing, open the SLAM GO app on your phone and click on the **S-RTK** icon below to enter the RTK work page.
- 4) Click on **Disconnected** above, and SLAM GO will automatically connect to the Bluetooth pairing successfully for S-RTK100A devices, the device status bar will display in sequence: **Disconnected** → **Scanning** → **Connected**. When the icon displays **Connected**, the device is successfully connected to the phone.

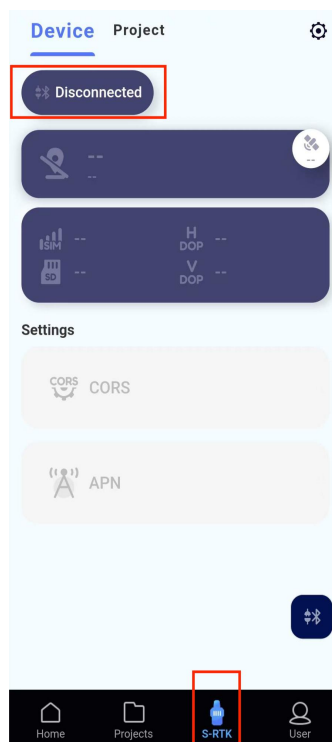

Connection status - device connected

If the device status changes from being scanned to not connected after clicking on the device status bar area, please check whether the S-RTK100A power on status, device power supply status, and APP Bluetooth permissions have been successfully opened.

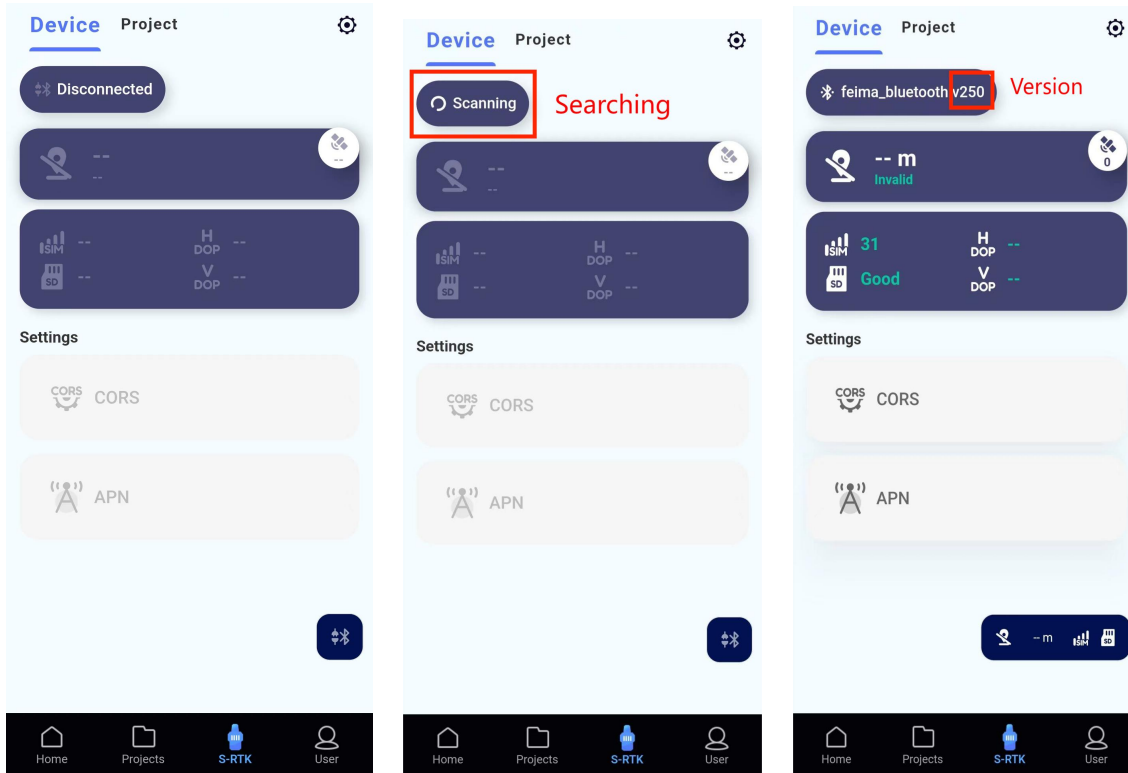

How to open Bluetooth permissions

For example, Xiaomi mobile phone: Open **Settings - Application Settings - Application Management** - Find **SLAM GO** and click **Enter - Permission Management** - Set permissions such as enabling Bluetooth and connecting to nearby devices to always allow. (Other brands of Android phones operate similarly)

Connection status - Bluetooth off

If Bluetooth is not turned on in the Searching, SLAM GO will automatically turn on Bluetooth after obtaining permission.

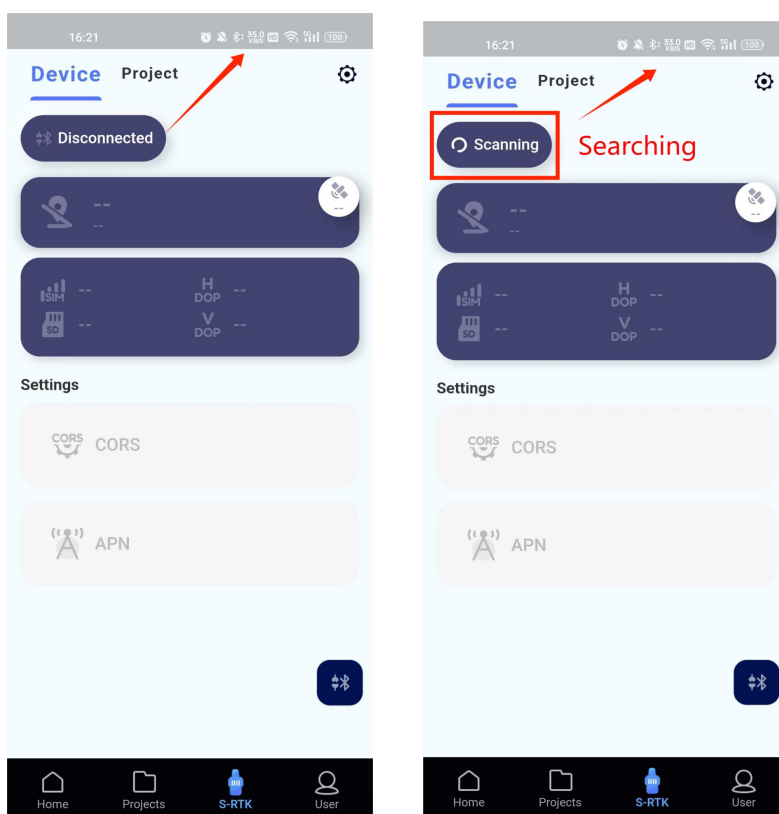

Disconnect S-RTK100A

Click on the device status bar **Connected** → pop-up **Disconnect** → click on **Disconnect** in the pop-up window to disconnect the Bluetooth connection of the S-RTK100A device.

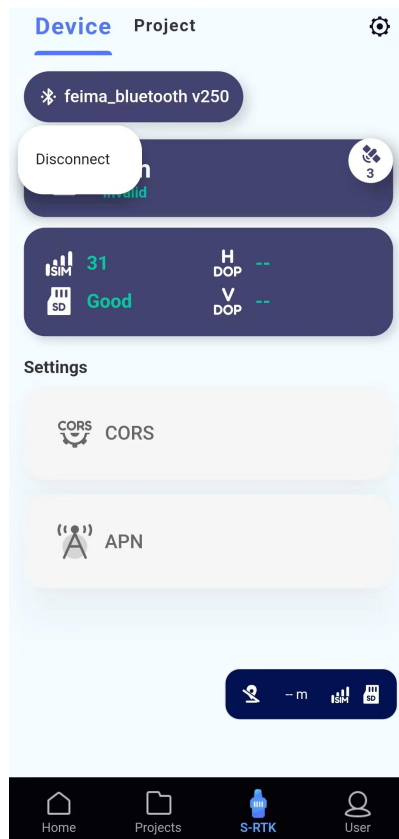
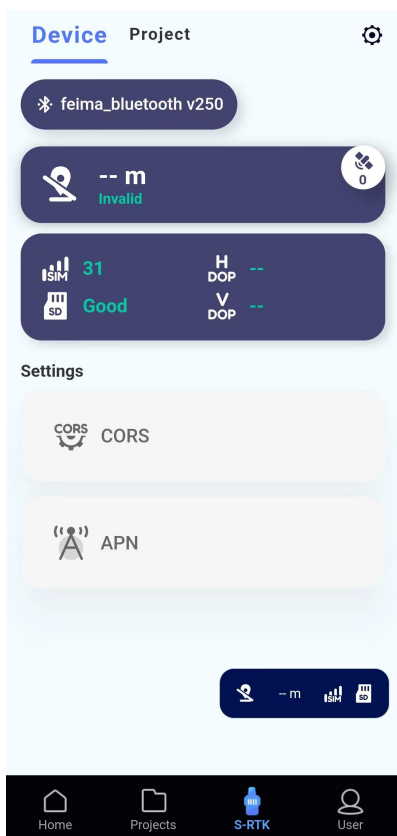

Device status

After connecting.

From the device to the APP, you can view the real-time status of the S-RTK100A device on the homepage of the S-RTK column. The device status bar information includes the number of satellites in search, GPS fixed solution status, H-DOP value, V-DOP value, SIM card status, SD card status, Bluetooth connection status, Bluetooth name, and S-RTK firmware version.

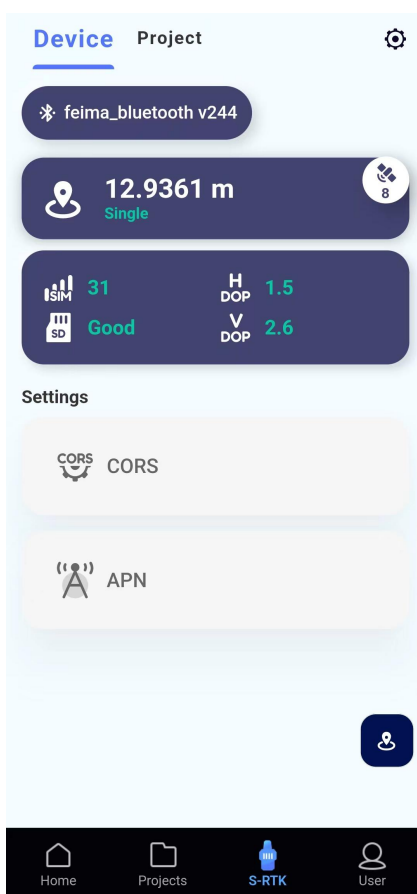

Open the floating window of status

The status floating window can be suspended in the form of a floating window on any interface of the APP, making it easy to view the real-time status of S-RTK100A devices (fixed solution, P-DOP, SIM, SD card, etc.) at any time within the APP.

- 1) Enter the S-RTK section of the app, click the settings button in the upper right corner, and enter the page of the open status of the floating window.
- 2) Click on the middle part of the open status of the floating window bar to open the display of the status of the floating window.
- 3) Click on the floating window to zoom in and out on it.

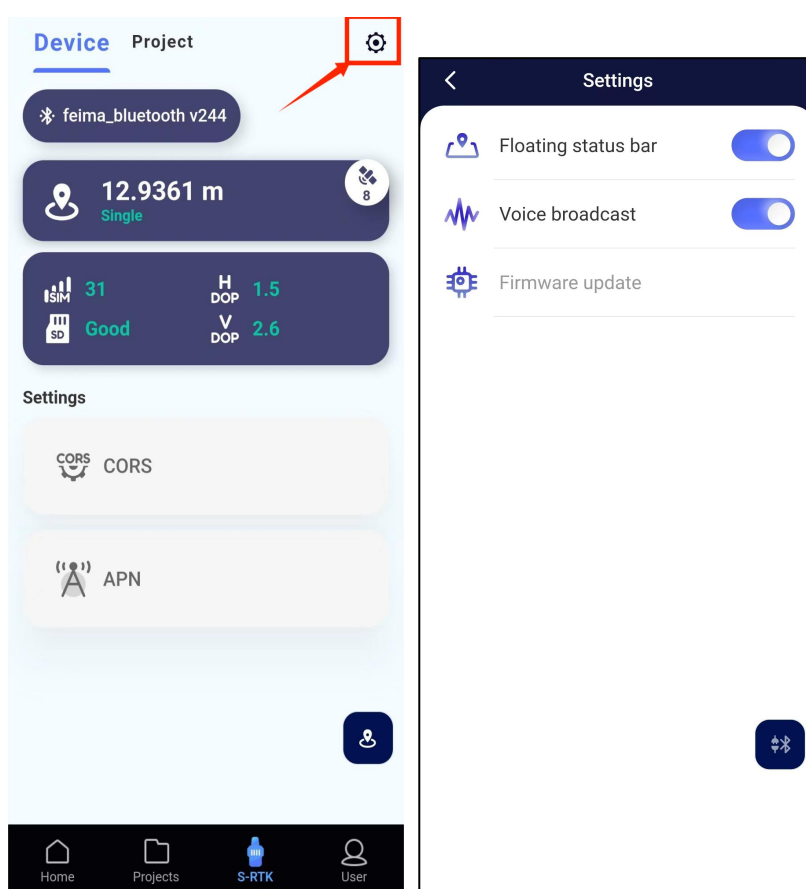

Enable the voice broadcasting

Voice broadcasting can provide real-time voice reminders when the device status changes. Enter the S-RTK page, click the setting button in the upper right corner of the interface, and enter the secondary menu to control the switch of voice broadcasting (default on).

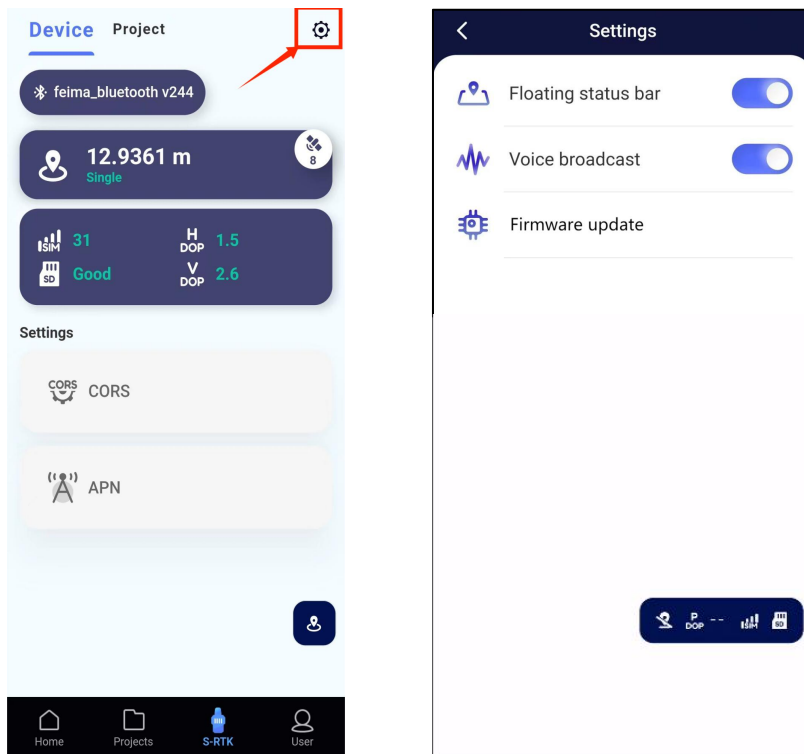

Number of searched satellites

The number of satellites that have been searched by the current S-RTK100A device is marked in the device status bar.

Notice!

- When the device is in static station measurement or point measurement, the number of searched satellites will be significantly reduced because the number of search satellites on the homepage is the number of satellites participating in the calculation.



Horizontal Standard Deviation

Horizontal standard deviation indicates the degree of dispersion of a set of horizontal coordinate measurements. The smaller the value of horizontal standard deviation, the higher the consistency between measurements and the higher the positioning accuracy.

(The value of horizontal standard deviation in the figure below is 0.0241 m.)

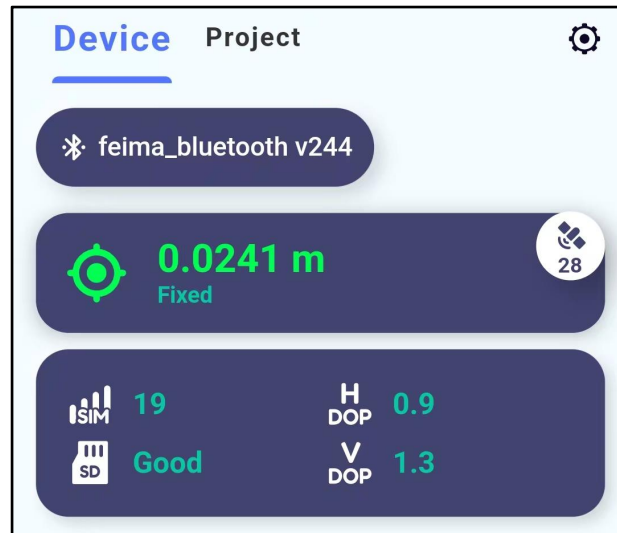

GPS solution status

The **Solution Status** of the S-RTK100A device includes invalid solution, single point solution, floating point solution, and fixed solution.

- Invalid solution: The device cannot locate and receive satellite signals.
- Single point solution: Indicates that differential data has not been received, with the lowest accuracy, usually within 10 meters.
- Floating-point solution: Refers to the preliminary solution obtained by receiving the reference station differential and solving the carrier phase differential data, with high accuracy, generally within 0.5 meters.
- Fixed solution: Refers to the final solution obtained by receiving differential data from the reference station and solving the carrier phase differential data, with the highest accuracy, generally within 0.02 meters. When conducting high-precision GPS measurements, it is necessary to reach a fixed solution state to record data.

Invalid solution

If the device status bar displays invalid solutions and the first indicator light of S-RTK100A flashes red, it indicates that the device cannot receive satellite signals and cannot locate at this time.

The occurrence of this situation is constrained by many factors, the most important of which are signal and motion status. It is often difficult to locate S-RTK100A in areas with poor satellite signals (such as indoors, in tunnels, and in urban neighborhoods with towering buildings), or when in motion.

Suggestion:

- 1) Check if the SIM card is properly inserted and there are no abnormal conditions such as overdue payments or downtime.
 - 2) Update the SLAM GO software version and the firmware.
 - 3) Shut down and restart S-RTK100A to search for and locate satellites again.
 - 4) If it is still unable to locate, it is recommended to change to another spacious location or try again at a different period.
- ※ If the above method still displays an invalid solution after the operation, we suggest that you promptly contact the official after-sales service of Feima Robotics to communicate and resolve the issue.

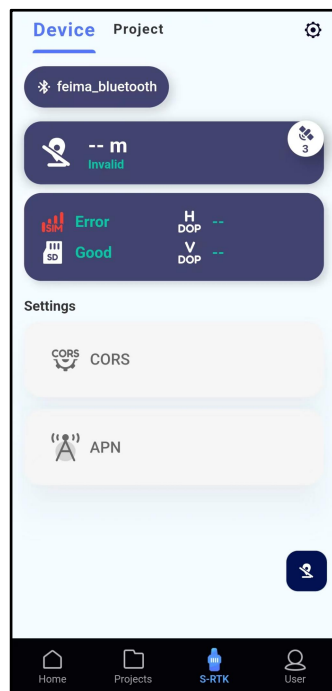

Single point solution

If the device status bar displays a single-point solution and the first device indicator light of S-RTK100A is red, it indicates that the device is currently in a single point solution state.

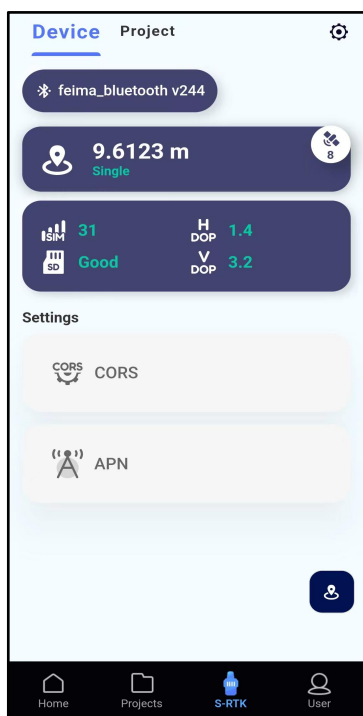

Pseudo range solution

If the device status bar displays a pseudo-range solution, it indicates that the device has entered pseudo range positioning mode.

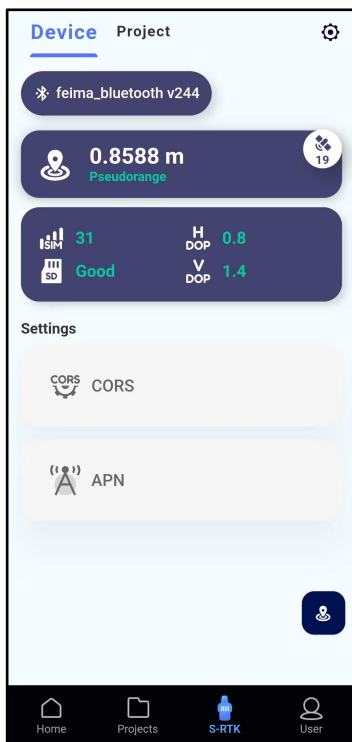

Floating-point solution

If the device status bar displays floating point solution and the first device indicator light of S-RTK100A flashes green, it indicates that the device has currently entered the floating point solution state.

(Notice! To access the floating-point solution, you need to connect to a CORS account. Go to the **S-RTK - CORS** - Enter CORS account password - Click to obtain the source node - Select a source node - Click Save - Prompt to save successfully.)

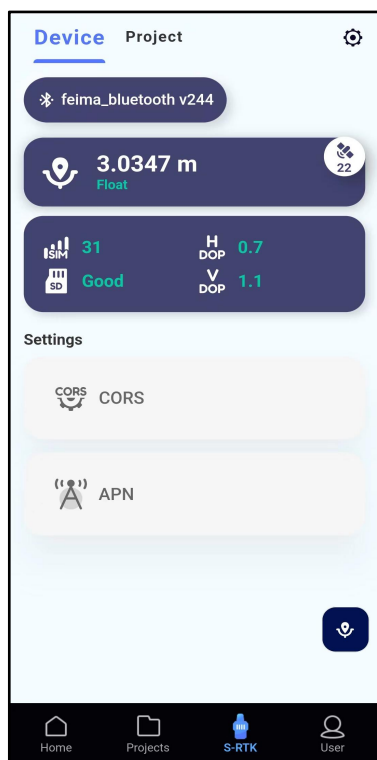

Fixed solution

If the device status bar displays fixed solution and the first device indicator light of S-RTK100A remains green, it indicates that the device has entered the fixed solution.

(Notice! To access the fixed solution, you need to connect to a CORS account. Go to the **homepage - Settings - CORS** - Enter CORS account password - Click to obtain the source node - Select a source node - Click Save - Prompt to save successfully.)

Notice! The fixed solution display at the floating window indicates that the device has currently entered a fixed solution state. Notice! High/low precision fixed solution differentiation method:

- Low-precision fixed solution displayed in white.
- High-precision fixed solution displayed in green.

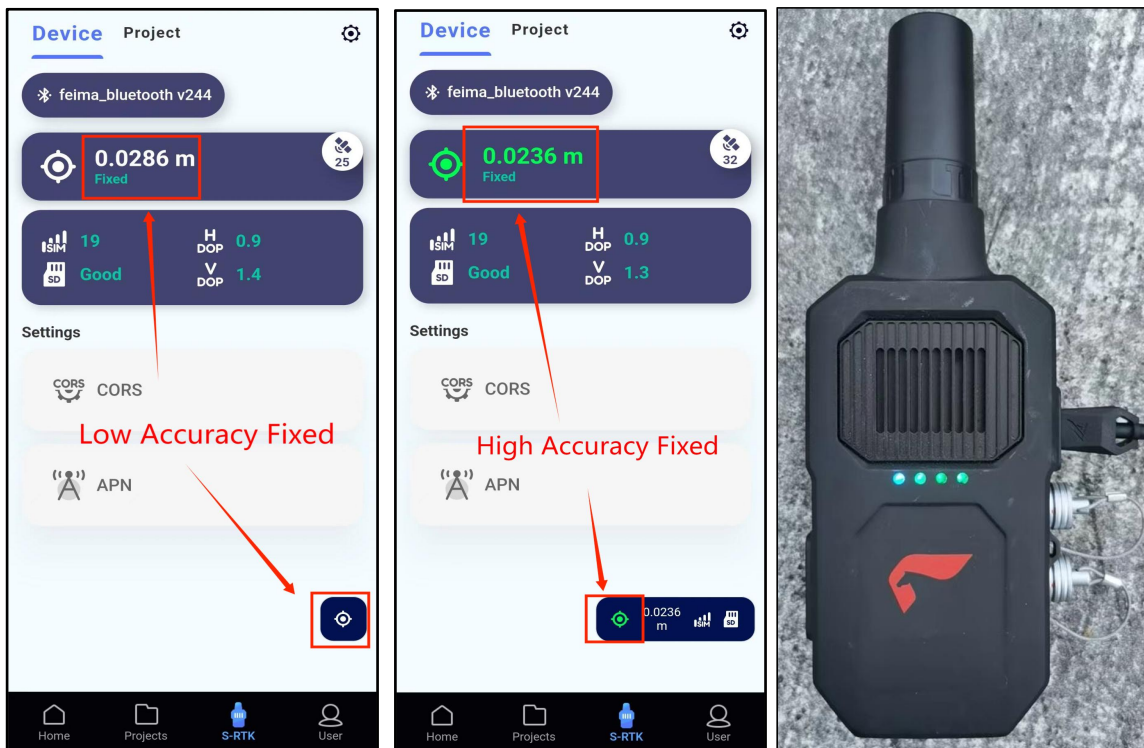
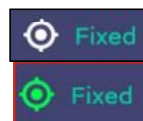

PDOP value

The PDOP value represents the intensity factor of satellite spatial geometric distribution, with a value less than 3 being the ideal state. A smaller PDOP value indicates a better intensity of satellite spatial position distribution, which is more conducive to quickly solving to a fixed solution state.

In the device status bar of the APP homepage, the two components of the PDOP value in the horizontal and vertical directions are displayed, namely the HDOP horizontal geometric distribution intensity factor and the VDOP vertical geometric distribution intensity factor.

As shown in the figure below, the satellite signal strength is good at this time. If HDOP/VDOP value is too high, please try replacing it with a spacious place to keep the signal antenna unobstructed.

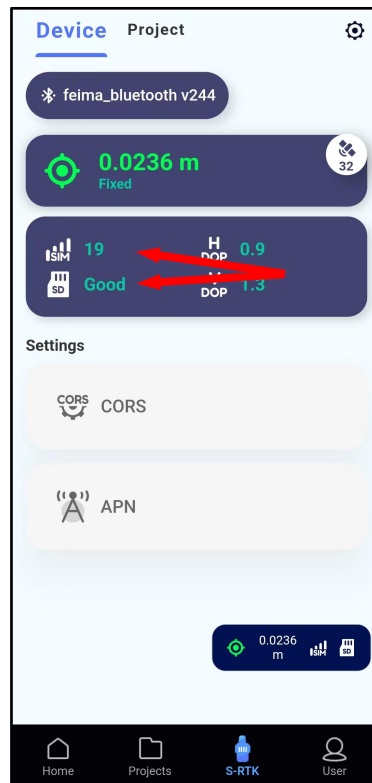

SIM card status

The signal quality of SIM cards can affect the quality of fixed positioning signal reception, and the speed and quantity of source node acquisition. A good SIM card signal can enhance the user experience of S-RTK100A.

As shown in the figure below, the higher the value of the SIM card, the better the SIM card signal quality (it should meet the requirements of 12-31).

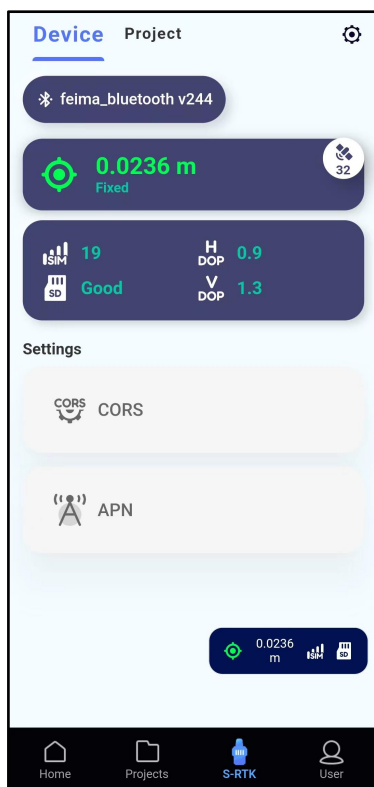

SIM card-related troubleshooting

If you encounter an abnormal display in the SIM card status bar as shown in the following figure, please troubleshoot in the following order:

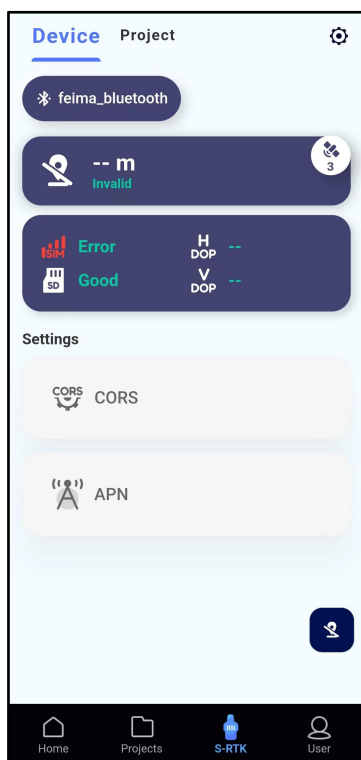

- 1) Check if the S-RTK100A has inserted the SIM card, and if there are two limit positions when inserting. After inserting, the SIM card should be flush with the card slot (the metal side of the SIM card should face the front of the S-RTK100A device to insert it correctly).
- 2) Check if there are any objects in the SIM card slot. If there are any objects, please clean them promptly.
- 3) Check whether the SIM card status is normal and whether the SIM card can access 4G internet normally. If there is an abnormality with the SIM card, please consult the network operator to which the SIM card belongs.
- 4) Check if the SIM card signal is normal. If the SIM card signal is weak, please try changing to a location with a strong open network signal and try again.
- 5) Try to replace a SIM card that ensures normal status, insert the device, restart the device, and connect to the app and try again.

If the SIM card abnormality still appears after the above operation, we suggest that you promptly contact the official after-sales service of Feima to communicate and resolve the issue.

MicroSD card status

To use the S-RTK100A device, a TF card needs to be inserted, in order to save the data and log files collected by S-RTK100A.

When inserting a TF card, it is necessary to insert the metal side of the TF card towards the front of the S-RTK100A device. After insertion, there is a clear sense of limit, and the TF card is flush with the card slot.

MicroSD card-related troubleshooting

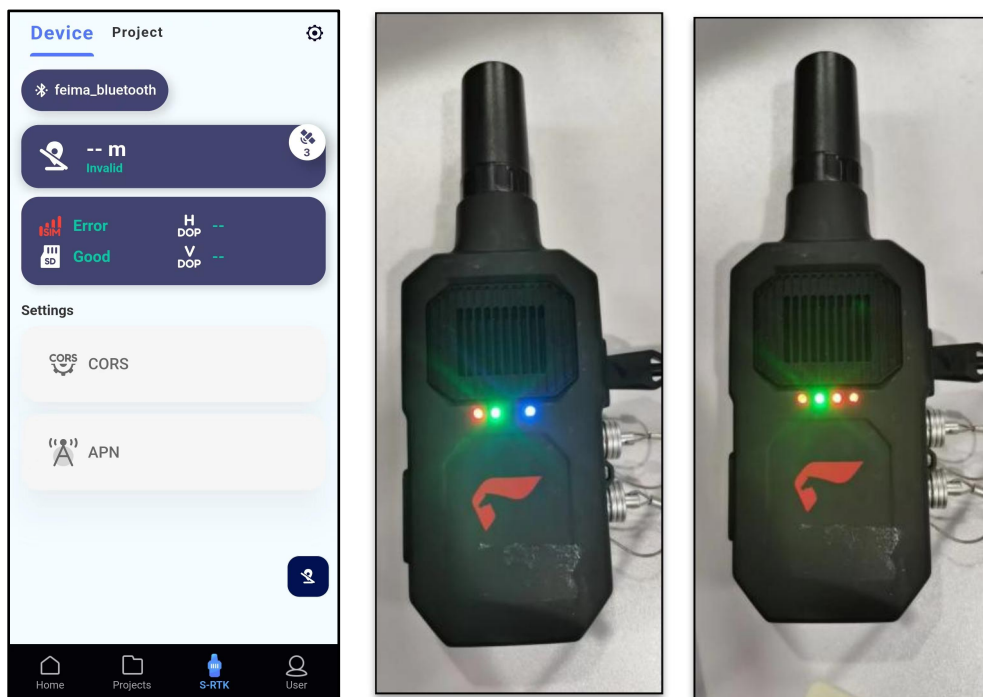

If the SD card display in the APP device status bar is abnormal, or if the fourth indicator light of the S-RTK100A device flashes red or blue, please troubleshoot in the following order:

- 1) Check if the MicroSD card is properly inserted, try unplugging and reinserting the MicroSD card after powering off the device, and then restart the device.
- 2) Check if the MicroSD card status is normal, ensure that the MicroSD card can read and write normally, and ensure that the MicroSD card has more than 4G of remaining space.
- 3) Update the SLAM GO software version and firmware version of S-RTK100A.
- 4) Check if there are any objects in the MicroSD card slot. If there are any objects, please clean them in time.
- 5) Try replacing a MicroSD card that is in a normal state, inserting the device, restarting the device, and connecting to the app to try again.

If the MicroSD card abnormality still appears after the above operation, we suggest that you promptly contact the official after-sales service of Feima to communicate and resolve the issue.

Settings

Coordinate System Settings

Enter the **S-RTK** → **Setting** → **Coordinate System**, where you can view the parameters of ellipsoid parameters, projection, seven parameters, four parameters, and elevation fitting within the coordinate system.

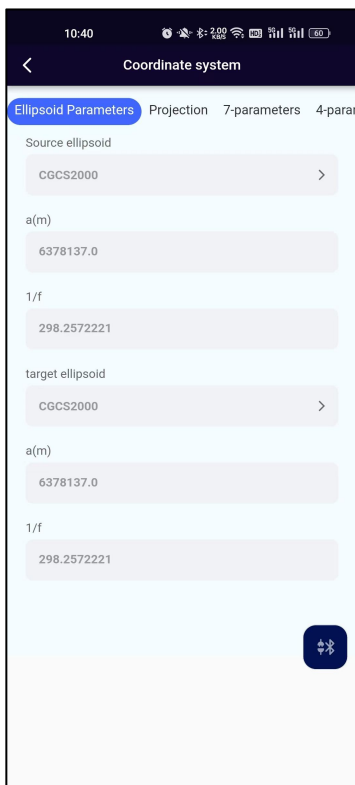

CORS settings

S-RTK100A needs to be connected to a CORS account for use, which is a prerequisite for S-RTK100A to carry out normal measurement work. The CORS system is used to improve surveying accuracy and enable the S-RTK100A device to enter a fixed or floating point solution state.

The connection information of the CORS account includes the connection address, port, source node, account, and password. The above connection information needs to be obtained by contacting the official after-sales service of Feima, or by oneself.

Notice!

The default server for CORS account settings is Thousand Location, and the default connection address is rtk.ntrip.qxwz.com. The default connection port is 8002. If you need to connect to the 8003 port, please manually set it.

Qianxun CORS Account Connection Process:

- 1) Open SLAM GO, enter the S-RTK homepage and find Settings - CORS Network.
- 2) Click to enter CORS settings, enter the CORS account and password for Qianxun Positioning.
- 3) Click the Get Source Node button, select a source node from the pop-up source list, and click OK.
- 4) Click Save and a pop-up window will prompt that the CORS account has been successfully set.

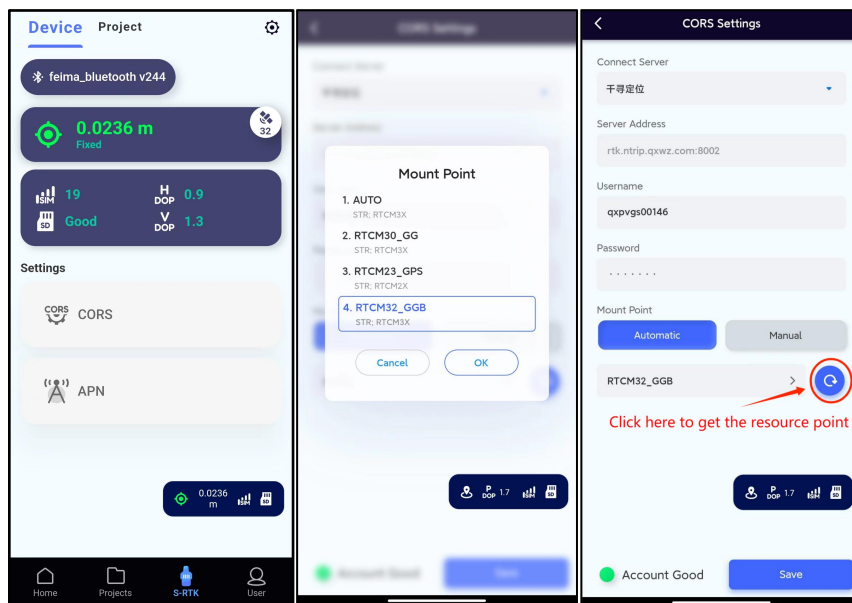

Other CORS account connection processes:

- 1) Open SLAM GO, enter the S-RTK homepage and find Settings - CORS Network.
- 2) Click to enter the CORS network, press the button on the right side of the connection server input box to open the drop-down list, click the button +, enter the CORS account label, connection address, and connection port in the custom interface, and click the button ✓ below
- 3) Return to the previous level, open the server drop-down list, and click to select the custom server you just saved.
- 4) Enter your account and password, click  Get Mount Point, select a mount point in the list, and click OK.
- 5) Click the save button at the bottom right of CORS settings, and a pop-up window will prompt that the settings have been successful, indicating that the CORS account has been successfully set.

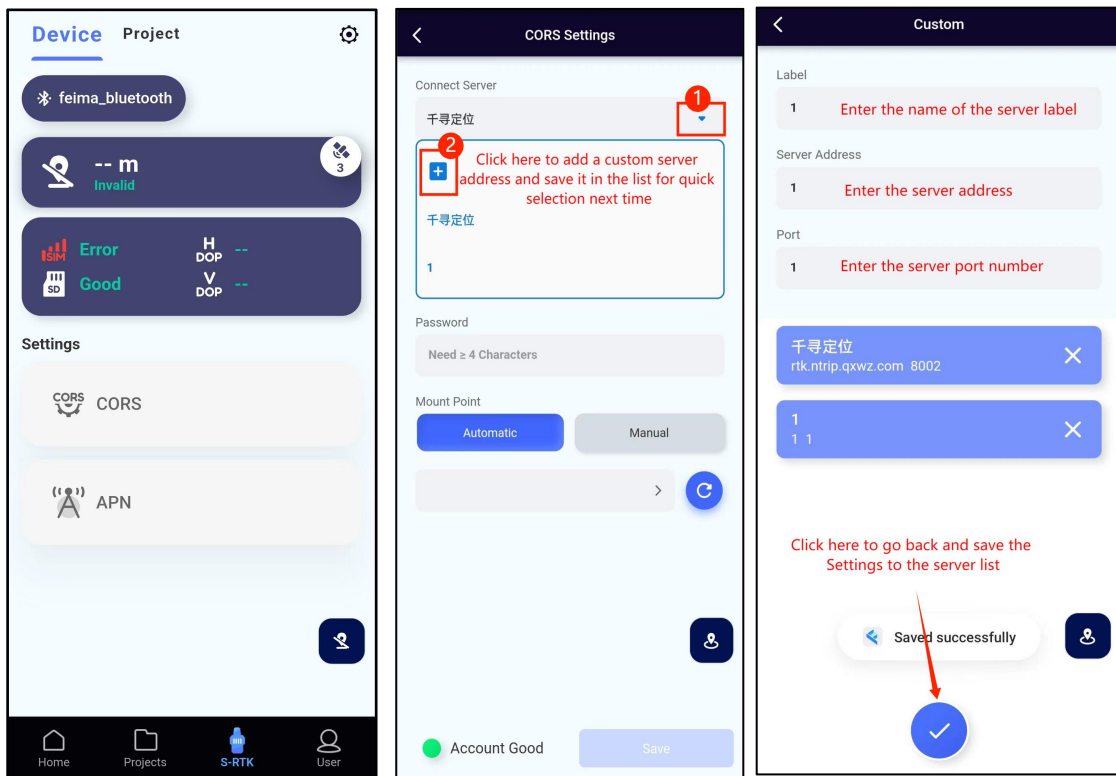

Notice!

To ensure the normal operation of S-RTK100A, after successfully connecting to SLAM100:

- 1) Ensure that S-RTK100A is turned on in an open and outdoor environment with GNSS signal.
- 2) After the S-RTK100A is turned on, it needs to carry out time auto-calibration and star search, and at this stage, it needs to wait for a few seconds to a few minutes (the waiting time depends on the GNSS signal strength). It is recommended to wait for about 20 seconds to stabilize the signal after the fixed solution. It is recommended to wait about 20 seconds to stabilize the signal after the fixed solution.
- 3) The SLAM100 can only operate normally when the GNSS indicator light is **green flashing** or **green light is constantly on**.

Notice!

- 1) According to local radio regulations, please use the S-RTK100A satellite signal receiver in the corresponding frequency band and comply with local radio laws and regulations.
- 2) When using and placing, please ensure that the S-RTK100A remains perpendicular to the ground (with the antenna facing upwards).
- 3) Try to avoid using S-RTK100A in obstructed or radio interference environments.
- 4) Please ensure that the antennas of all devices are not obstructed during use.
- 5) Please keep the equipment away from liquids such as water and oil.
- 6) Pay note to lightning protection.

APN Settings

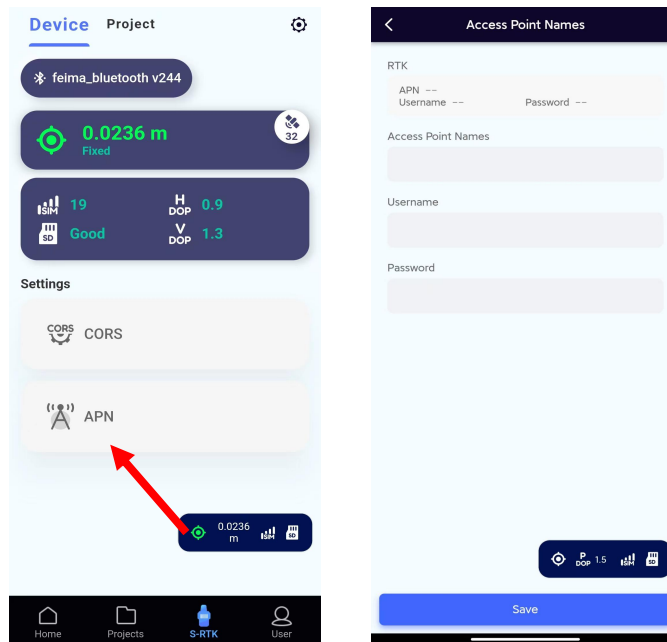

APN, also known as **Access Point Names**, must be set through mobile APN when using mobile LTE networks. It is a parameter that must be configured when using mobile internet.

APN settings can be divided into three situations:

① Chinese operators ② Foreign operators ③ Manually setting access points

1. Chinese operator: 4G module features based on S-RTK100A: For Chinese operators, their APN can be set to blank.
2. Foreign operator: If you use foreign operator services without setting up an APN, you may not be able to access the internet. Therefore, when using it for the first time abroad or after switching SIM cards from different operators, it is necessary to connect to the SLAM GO app for automated settings.
3. Manual setting of access points: APN may need to be manually set in the following scenarios:
 - 1) Some LTE networks in Chinese private networks require manual setting of APN.
 - 2) When the corresponding APN settings cannot be obtained for certain different regions or countries.

At this point, you need to manually enter the APN access point address (the access point needs to actively contact the relevant operator to obtain it), enter the account and password, and click **Save** to successfully set it.

Notice!

- After the APN is set correctly, the firmware will automatically record relevant information. After the next boot, the device will automatically set without the need for repeated operations.

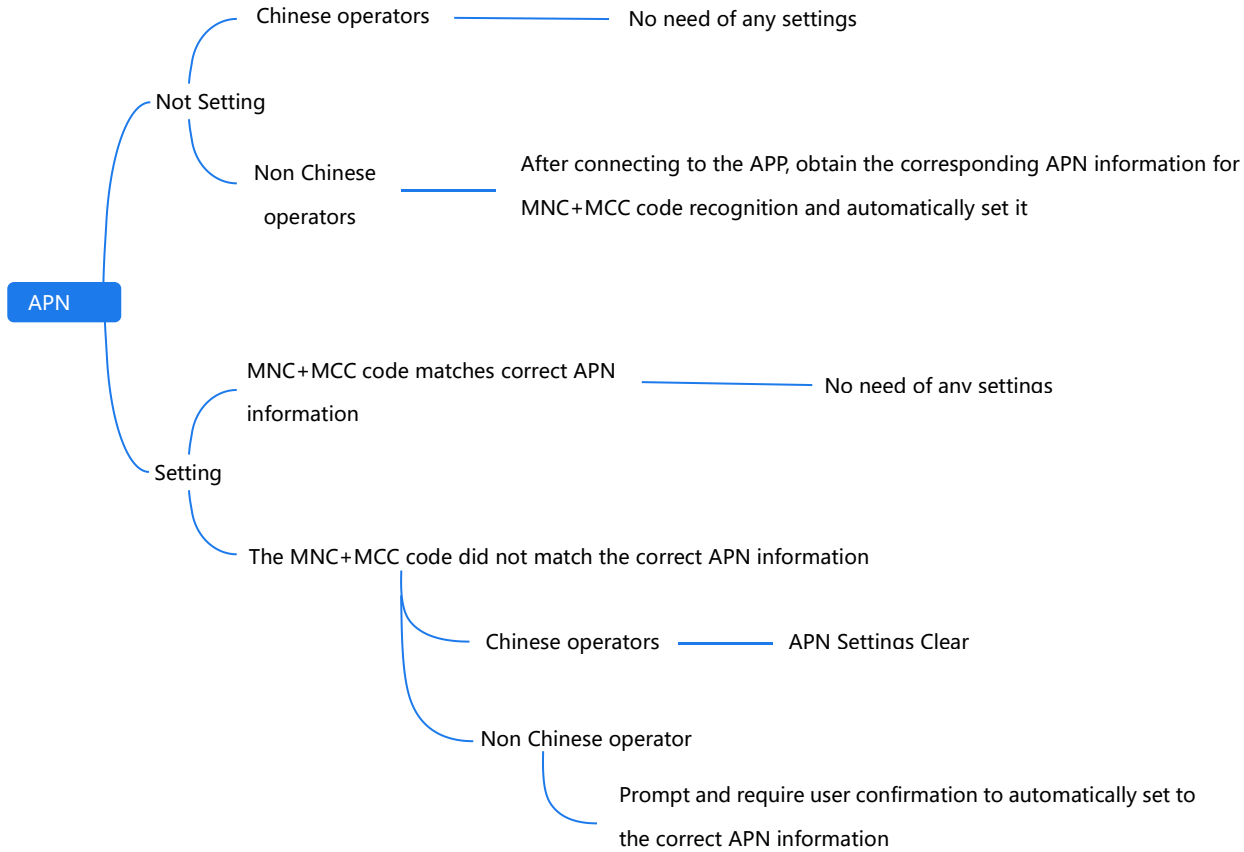

File

The File contains a point coordinate library and file export function, which is used to save the file information of points coordinates and export all file information of specified projects to the local location of the phone.

Coordinate point library

The coordinate point library function includes functions such as creating new points, expanding points, single/multiple selections and deletion of coordinate points, number of coordinate points in the point library, viewing coordinate point details, modifying coordinate point antenna height, and taking photos to mark coordinate point positions.

New Coordinate Point

Click on the SLAM GO homepage → **S-RTK** → **Project** → **Repository** → Click on the **New** button at the bottom left.

Then fill in the point name, select the point type, fill in longitude, fill in latitude, and fill in geodetic height. Click the Save button to pop up a prompt indicating that the save was successful, and a new coordinate point can be successfully created.

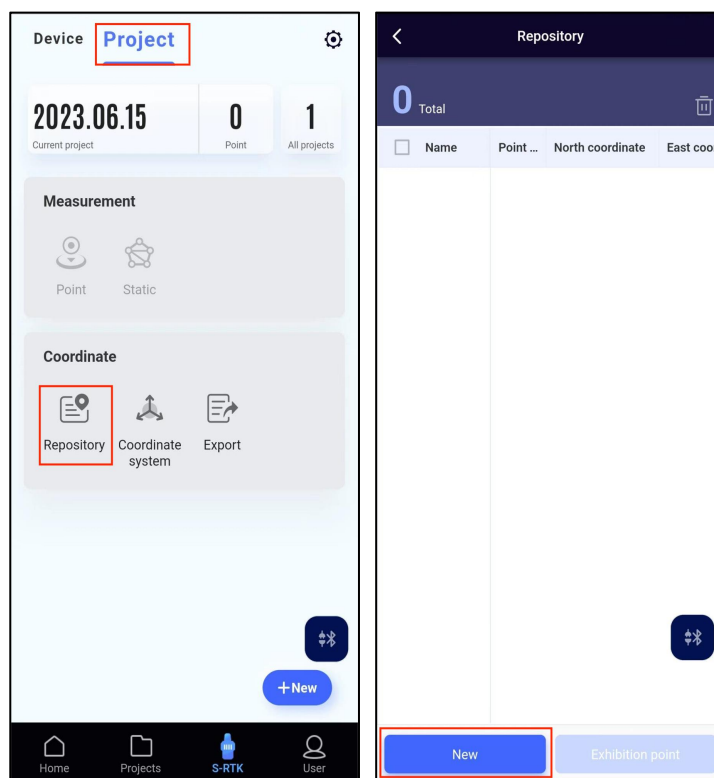

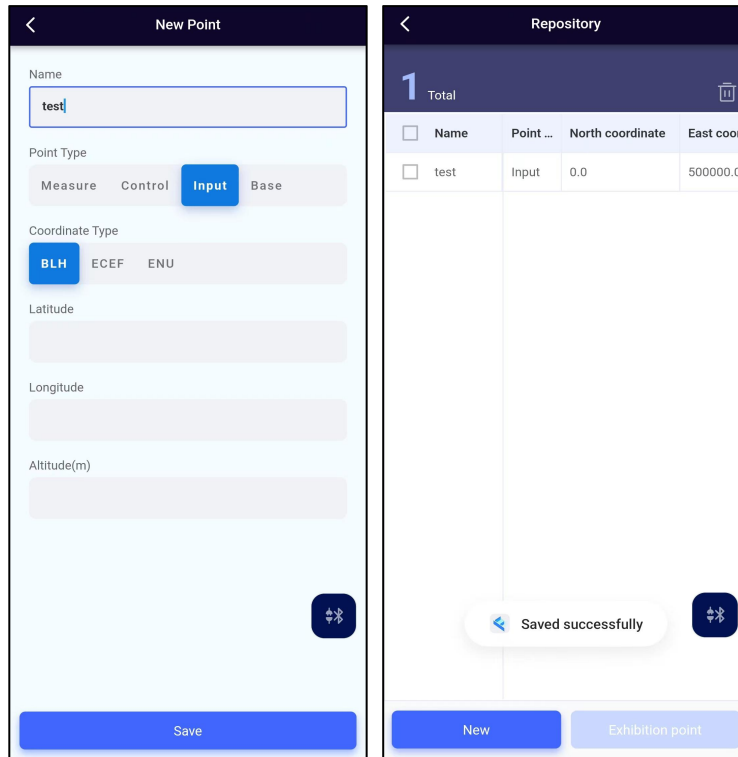

Point Distribution

1. This function can display the coordinate points in the coordinate point library on the map, making it easy to locate the location of the coordinate points.
2. Click **S-RTK** → **Project** → **Coordinate System** → Check a coordinate point → Click the **Expand Point** button at the bottom left.
3. Click the **Switch Tiles** button at the bottom right of the display interface to switch the display of tile maps.

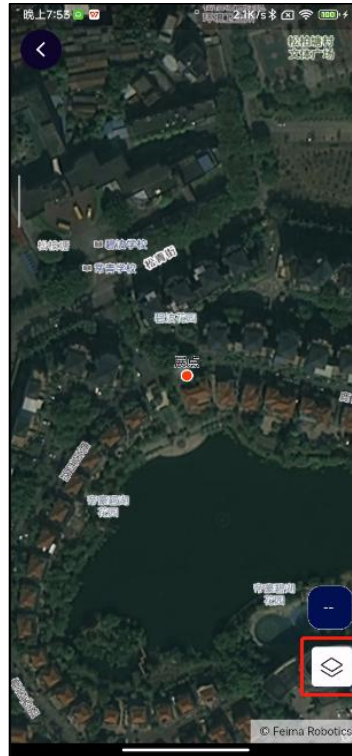
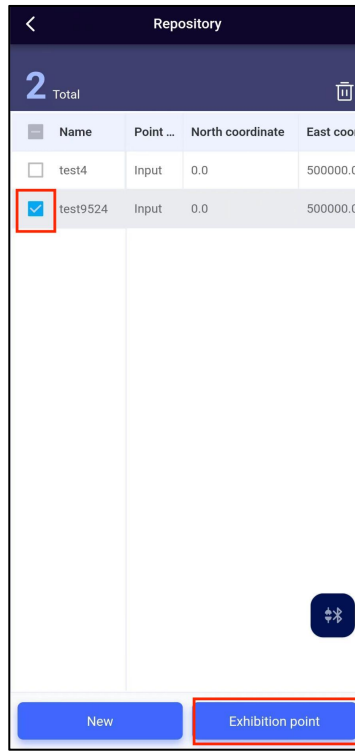
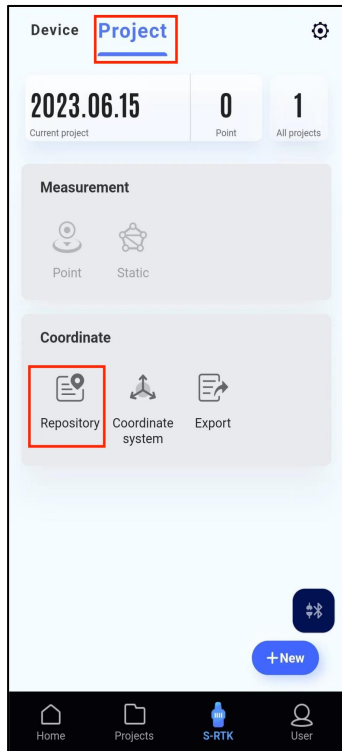

Coordinate point single/multiple/all selection delete

This function can delete unnecessary coordinate points in the coordinate point library. You can select or batch delete coordinate points by clicking the check box in front of the coordinate points in the coordinate point library interface.

Click on SLAM GO homepage → S-RTK → Project → Repository → Check one or more

coordinate points (to select all coordinate points, click the check box before the point name in the title bar to select all coordinate points) → Click on the **Delete** button in the upper right corner → Click OK in the pop-up window to delete unnecessary coordinate points.

Notice!

- Care should be taken when deleting coordinate point data, as it cannot be restored after deletion.

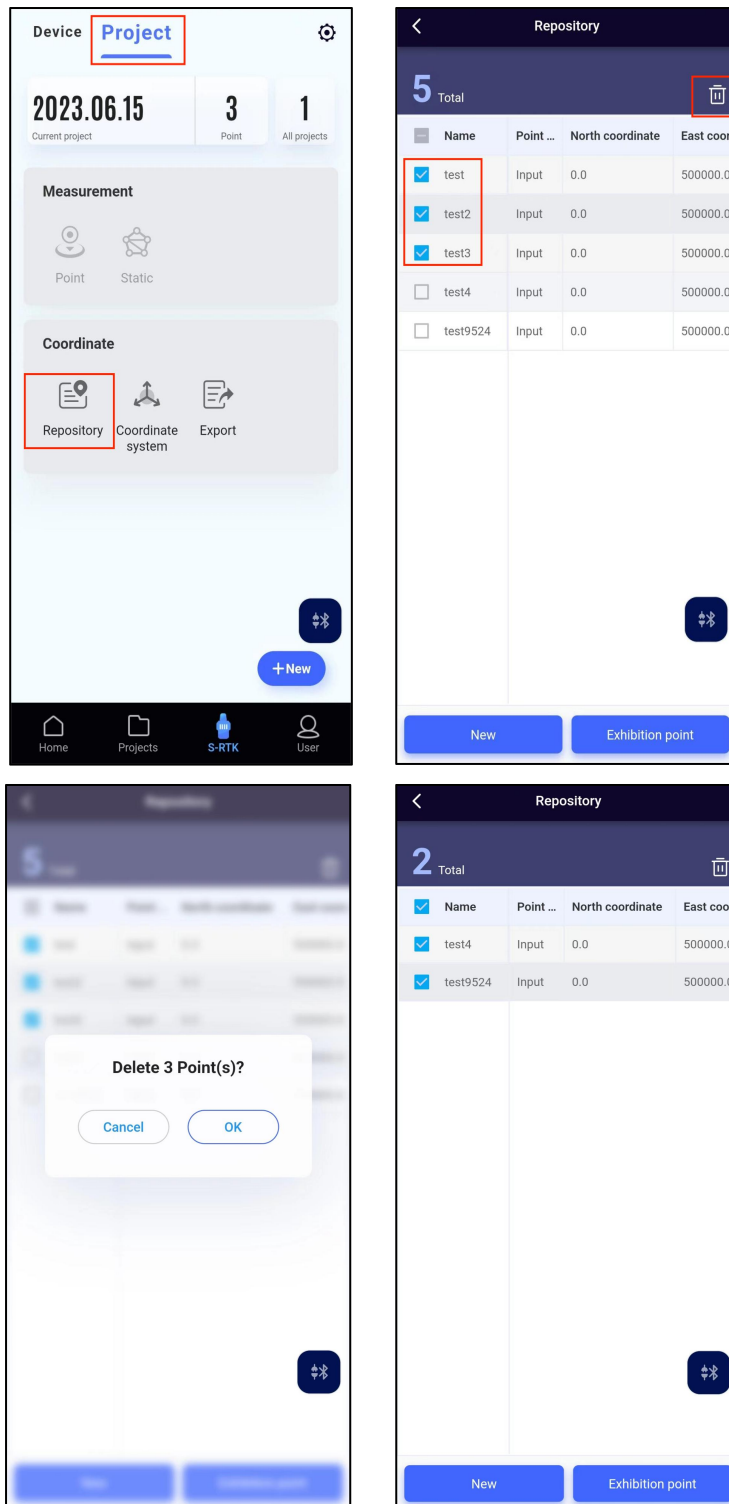

Display of the number of coordinate points in the point library

Display the total number of coordinate points in the current coordinate point library.

Click on **S-RTK** → **Repository**. The number before the **Total** in the upper left corner of the page represents the total number of coordinate points in the current coordinate point library.

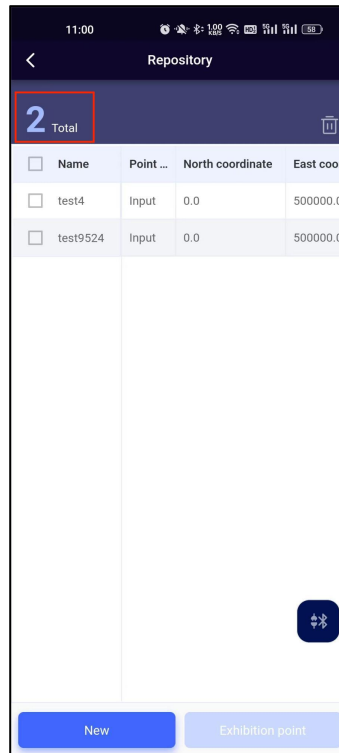
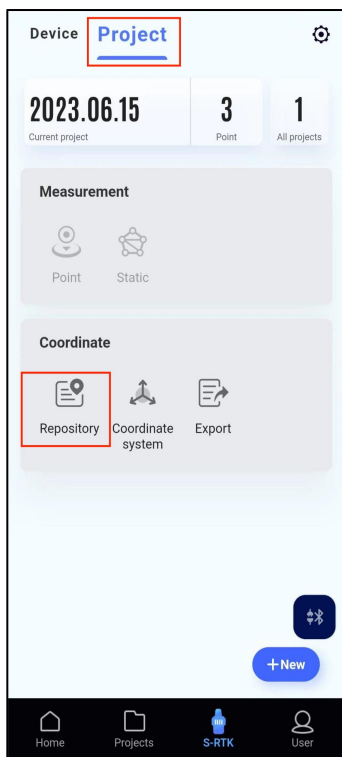

View/Modify Coordinate Point Details

On the coordinate point library interface, slide the coordinate point list left and right to view the point type, north coordinate, east coordinate, elevation, latitude, longitude, geodetic height, and number of image markers of the coordinate points.

Enter the coordinate point library interface, and slide the coordinate point list left and right to quickly view coordinate point information.

Alternatively, click on **S-RTK** → **Project** → **Repository**. Click on a coordinate point in the coordinate point list to enter the coordinate point details interface (click on the second image area below to enter the coordinate point details interface).

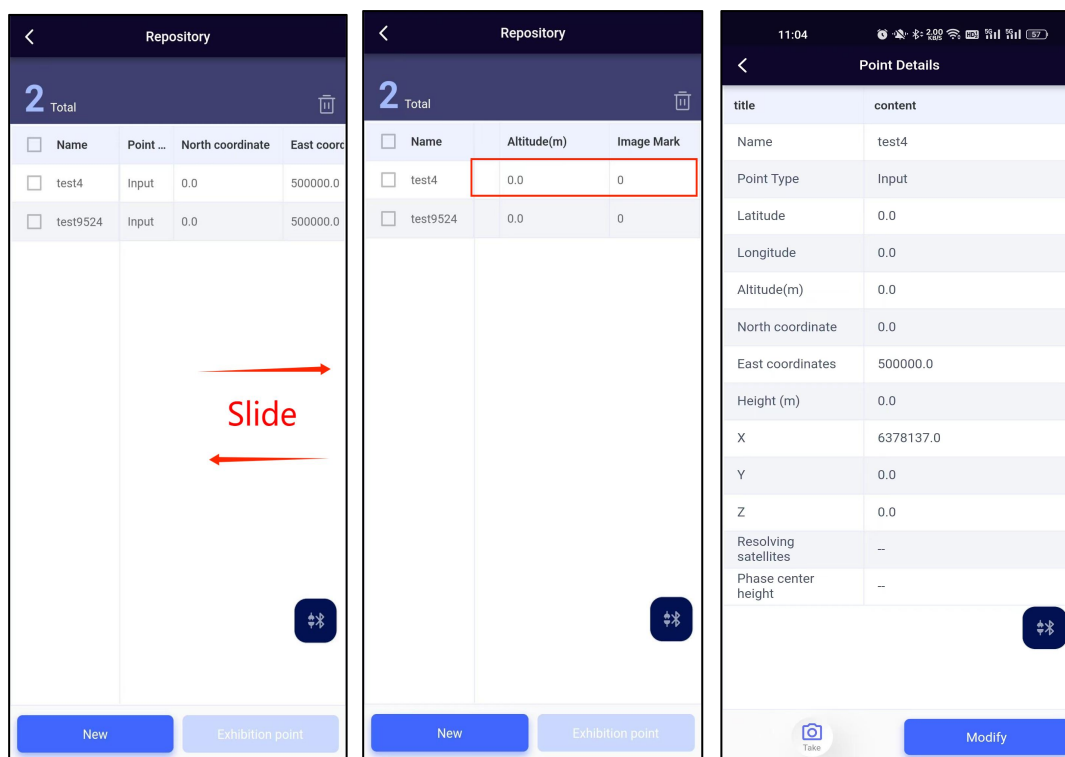

Modify the coordinate point antenna height (geodetic height)

When confirming the ground height, it is necessary to subtract the antenna height of S-RTK100A from the measured value of S-RTK100A to obtain the actual ground height. Therefore, it may be necessary to modify the antenna height before measurement.

Enter the coordinate point library page, select the coordinate point to be measured, click to enter the point details interface, click the **Modify** button at the bottom right, enter the antenna height, and click Save.

Notice!

- The antenna height is based on the height from the measurement point to the bottom of the S-RTK100A device.

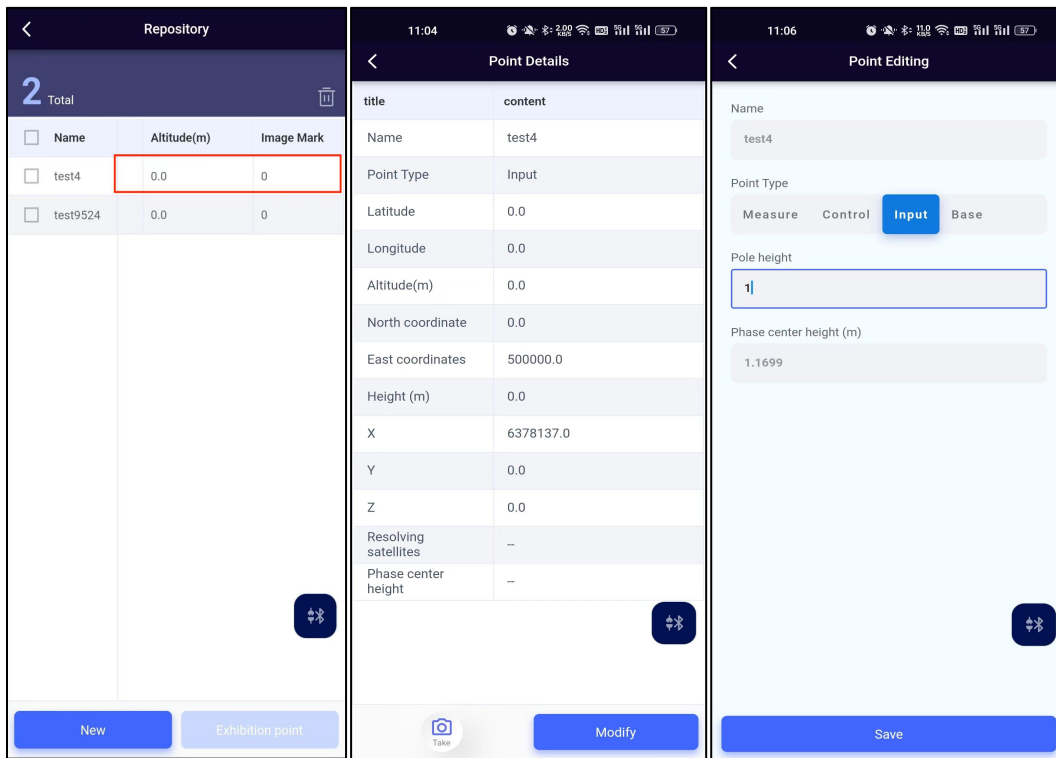
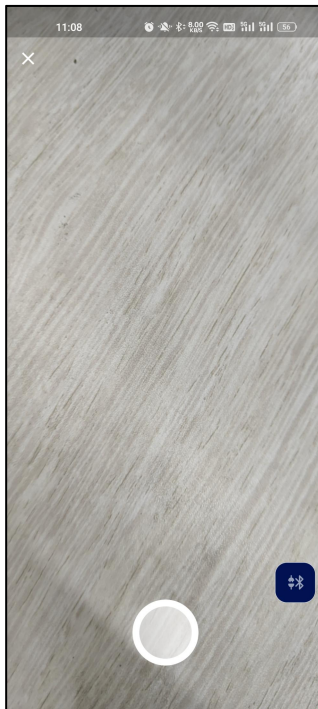
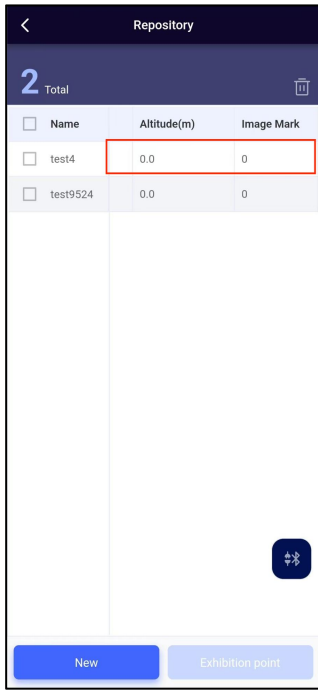

Image labeling

The image marking function is to facilitate the image marking of the measurement location, and to use the mobile phone photography function to mark the position of the measured coordinate points.

- 1). Click **S-RTK** → **Project** → **Repository**. Click on a coordinate point in the coordinate point list that needs to be marked with an image.
- 2). Enter the coordinate point details interface - click on the photo button at the bottom left (if there is already an image, you can click on the thumbnail in the bottom right corner to enter the photo marking interface again, where you can mark coordinate points with multiple images) (If the camera/recording permission authorization window pops up, please click **Allow**, otherwise it may cause abnormal image marking function).
- 3). Click the photo button in the middle of the interface.
- 4). Click Save on the pop-up interface.
- 5). You can return to the **Point Details interface** by using the phone's side swipe gesture or the return button in the upper left corner.



Export

This function allows you to export all relevant project information of the selected project to your phone's local location, making it easy to process and view data locally.

- 1). Click **S-RTK** → **Project** → **Export**.
- 2). Select the project to be exported and click OK.
- 3). Click Export (if the storage permission authorization window appears in the mobile system, please click Allow, otherwise the export function cannot be used normally).
- 4). The prompt indicates successful exportation. The file path at the pop-up window is the file directory path where the project file was derived to the phone. The exported project file can be found locally on the phone at this path.

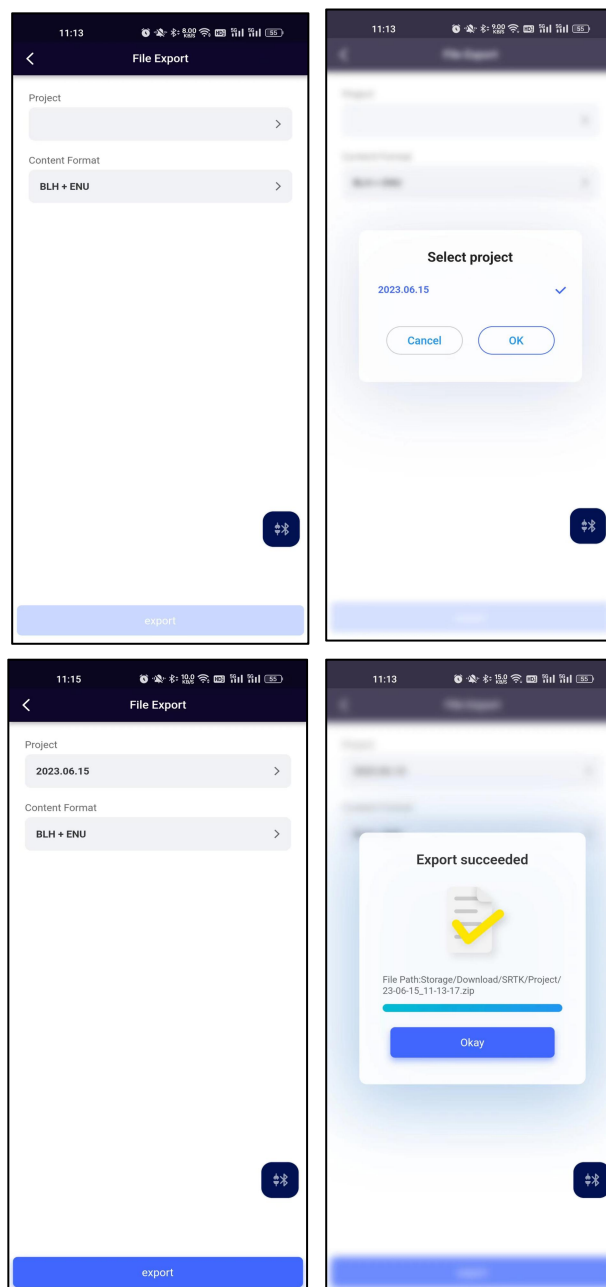

Measurement

The measurement function includes static station measurement and point measurement functions.

Static station measurement

Static station measurement refers to the installation of S-RTK100A as a receiver at a fixed position within a certain period, receiving multiple satellite signals, recording the receiving time of each satellite signal and the position information of the satellite, and then exporting and processing this data. By comparing the difference between the satellite signals received by the reference station and the mobile station, the position of the mobile station is calculated. Static station survey is usually used to establish high-precision geodetic control points, cartography, land survey and other fields, with the advantages of high precision, good reliability, high stability and so on.

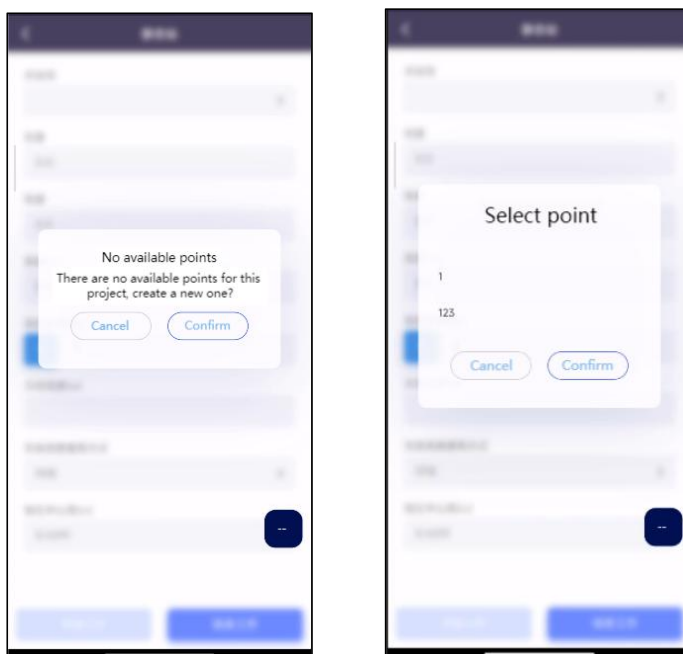

- 1) Enter the **SLAM GO** → **S-RTK** page.
- 2) Click on homepage → **Project** → **Static** → click on **Point Coordinates**.
- 3) Select a coordinate point → click the **Confirm** button.
- 4) Select a sampling frequency of 1/5 Hz.
- 5) Fill in the antenna height.
- 6) Click to start working.

If the device status bar displays **Static Station** at this time, it indicates that S-RTK100A is currently conducting static station measurement work.

Notice!

- To enter the static station for measurement, the first step is to connect the CORS account, so that the S-RTK100A device can enter a fixed or floating point solution state.
- If no new coordinate point is created before the work, it is necessary to create a new coordinate point according to the page guidance.

Stop static station measurement

Return to the static station measurement page and click **End Work** at the bottom right to exit the static station measurement work.

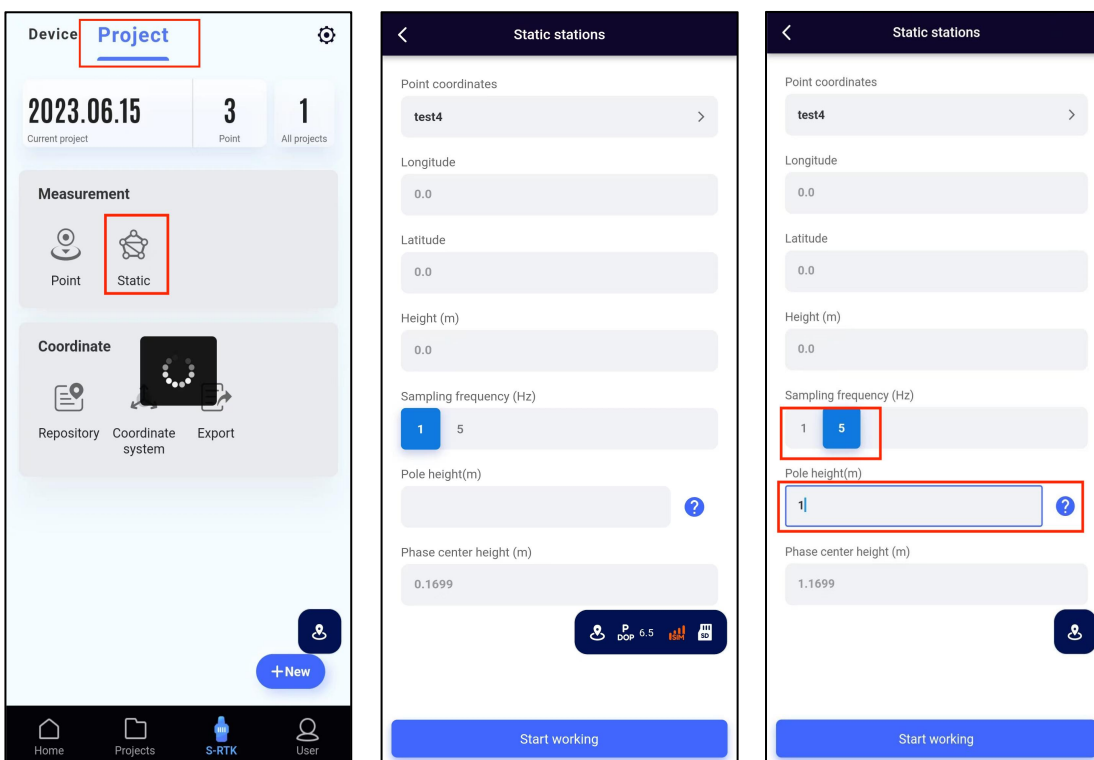

Point measurement

Point measurement is the real-time differential positioning sampling measurement of the point where the current position of the device is located, and the real-time calculation is carried out to obtain coordinate points with centimeter level accuracy.

To enter point measurement, first connect the CORS account, so that the S-RTK100A device must enter a fixed solution state.

- 1) Enter the **SLAM GO** → **S-RTK** page.
- 2) Enter the homepage → **Project** → Click on **Point**.
- 3) Enter a point name and select the sampling frequency (Notice! the larger the sampling frequency, the higher the accuracy of the sampled coordinate points, but the longer the sampling time. Please be patient and wait for the sampling to end).
- 4) Enter the antenna height and click **Start**.
- 5) Wait for the pop-up percentage to reach 100%, which means the measurement is complete. Please be patient and wait.

Interruption point measurement

In point measurement, slide the circle in the middle of the pop-up window from left to right to immediately cancel the point measurement.

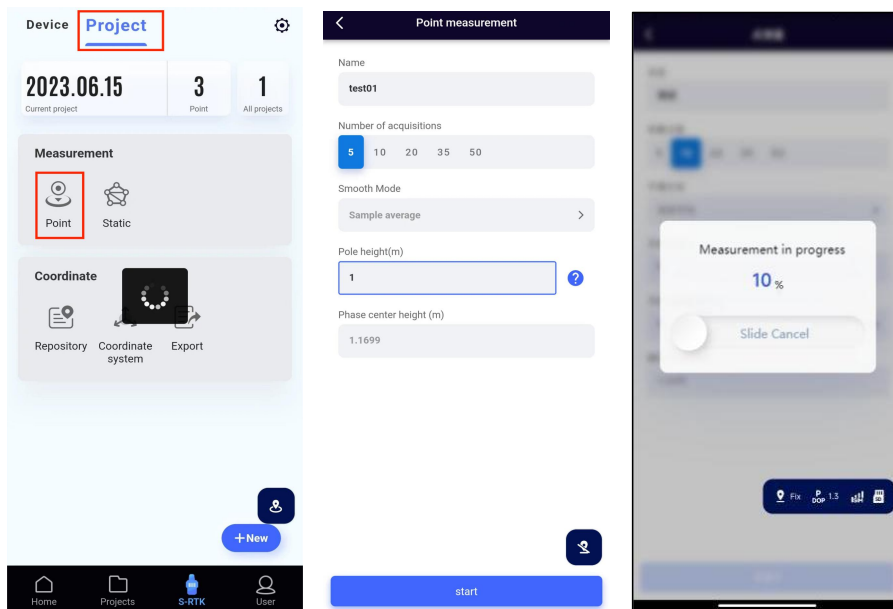

Contact us



Online Technical Support



Scan and follow WeChat
Feima Robotics Account



For more detailed product information, please visit the Cheese Industry Knowledge Base at the following website: <http://knowledge.cheesi.cn/>

If you have any questions or suggestions about the manual, please contact us via email: aftersales@feimarobotics.com

www.feimarobotics.com

Appendix-FCC Warning

FCC Warning

This device complies with part 15 of the FCC Rules. Operation is subject to the following two conditions:

(1) This device may not cause harmful interference, and (2) this device must accept any interference received, including interference that may cause undesired operation. Any Changes or modifications not expressly approved by the party responsible for compliance could void the user's authority to operate the equipment.

Note: This equipment has been tested and found to comply with the limits for a Class B digital device, pursuant to part 15 of the FCC Rules. These limits are designed to provide reasonable protection against harmful interference in a residential installation. This equipment generates uses and can radiate radio frequency energy and, if not installed and used in accordance with the instructions, may cause harmful interference to radio communications. However, there is no guarantee that interference will not occur in a particular installation. If this equipment does cause harmful interference to radio or television reception, which can be determined by turning the equipment off and on, the user is encouraged to try to correct the interference by one or more of the following measures:

- Reorient or relocate the receiving antenna.
- Increase the separation between the equipment and receiver.
- Connect the equipment into an outlet on a circuit different from that to which the receiver is connected.
- Consult the dealer or an experienced radio/TV technician for help.

Specific Absorption Rate (SAR) information:

This product meets the government's requirements for exposure to radio waves. The guidelines are based on standards that were developed by independent scientific organizations through periodic and thorough evaluation of scientific studies. The standards include a substantial safety margin designed to assure the safety of all persons regardless of age or health.

FCC RF Exposure Information and Statement

The SAR limit of USA (FCC) is 1.6 W/kg averaged over one gram of tissue. Device types: S-RTK100A (FCC ID: 2A7JA-S-RTK100A) has also been tested against this SAR limit. The highest SAR value reported under this standard during product certification for worn on the body is 0.498W/kg. This device was tested for typical body-worn operations 0mm from the body. To maintain compliance with FCC RF exposure requirements, use accessories that maintain a 0mm separation distance between the user's body.

Body-worn Operation

This device was tested for typical body-worn operations. To comply with RF exposure requirements, a minimum separation distance of 0mm must be maintained between the user's body, including the antenna. Third-party belt-clips, holsters, and similar accessories used by this device should not contain any metallic components. Body-worn accessories that do not meet these requirements may not comply with RF exposure requirements and should be avoided. Use only the supplied or an approved antenna.

This equipment contains specified radio equipment that has been certified to the Technical Regulation Conformity Certification under the Radio Law.